



WHEELCHAIRS FOR FUNCTION AND INDEPENDENCE

WWW.PDGMOBILITY.COM



Fuze T50

Fuze T50 / Fuze T50n

MANUAL TILT WHEELCHAIR

Owner's Operation and Maintenance Manual

DEALER This manual must be given to the user of the wheelchair.

USER Before using this wheelchair read this entire manual and save it for future reference.

Attendant/Assistants: Before assisting the user of this wheelchair, read this manual and save for future reference.

For more information regarding PDG products, parts, and service, please visit www.pdgmobility.com



1 INTRODUCTION

Thank you for purchasing a PDG mobility wheelchair.

Please do not operate this equipment without first reading and understanding this manual. If you are unable to understand the warnings and instructions, contact a health care professional such as an Assistive Technology Practitioner (ATP), clinical professional or therapist who is familiar with this type of product before attempting to use this equipment.

If you have any questions or comments about this manual, the safety and reliability of your wheelchair and the service you receive by us or your PDG supplier, please write or call us using the contact information below:

PDG PRODUCT DESIGN GROUP INC.
#103- 318 East Kent Avenue South, Vancouver, BC V5X 4N6
Ph: (604) 323-9220 Fax: (604) 323-9097
E-mail: info@pdgmobility.com

Please note and reference your product serial number when contacting PDG for us to better serve your customer support needs.

Serial Number:

SAVE THIS MANUAL FOR FUTURE REFERENCE
--

2 TABLE OF CONTENTS

1	INTRODUCTION	2
2	TABLE OF CONTENTS	3
3	NOTICE – READ BEFORE USE	5
4	SAFETY SUMMARY	6
5	SAFETY AND HANDLING OF WHEELCHAIRS	7
5.1	Stability and Balance	7
5.2	Tilting	8
5.3	Curbs and Steps	9
5.4	Stairways and Escalators	10
5.5	Transfers to and from Other Seats	11
5.6	Weight Distribution	11
5.7	Reaching, Leaning, and Bending Forward	12
6	ENVIRONMENTAL CONDITIONS	13
7	STANDARD FEATURES	14
8	UNPACKING AND ASSEMBLY	14
8.1	Inspection	15
8.2	Out of the Box Assembly Instructions	15
9	STORAGE	16
10	SAFETY INSPECTION CHECKLIST	16
11	MAINTENANCE	16
11.1	Cleaning	16
11.2	Suggested Maintenance Procedures	16
12	TROUBLESHOOTING	18
13	DAMAGE REQUIRING SERVICE BY QUALIFIED SERVICE AGENT	18
14	SETUP, ADJUSTMENTS & OPTIONS	19
14.1	Adjustment Guide	19
14.2	Seat Depth	20
14.3	Seat-To-Floor Height	21
14.4	Armrests	24
14.4.1	Dual Post Arms	24
14.4.2	Single Post Arms	24
14.4.3	Locking Flip-up Armrest	25
14.4.4	Armrest Pads	25
14.5	Front Rigging	26
14.5.1	Standard Front Rigging (Legacy) – Plug-in 70°, Swing-Away (70° and 90°), Swing Away Elevating Legrest (ELR)	26
14.5.2	Easy-Out™ Front Rigging Footrest Assembly – Plug-in 70°, Adjustable Knee Angle Front Rigging	29
14.6	Footplates	30

14.7	Heel Loops (Optional)	32
14.8	Padded Calf Strap (Optional)	32
14.9	Backrest Adjustments and Options.....	33
14.9.1	Angle/Height Adjustable Push Bar Handle	33
14.9.2	Fold Down Backrest (Not compatible with Reclining Back)	34
14.9.3	Reclining Backrest (Not compatible with Fold-down backrest)	34
14.10	Rear Wheels	35
14.10.1	Removing/Installing the Rear Wheels/Axles	35
14.10.2	Rear Wheel Axle Nut Adjustment (For Quick-Release Axles).....	36
14.11	Anti-Tippers.....	37
14.12	Front Casters.....	38
14.13	Wheel-Locks.....	38
14.14	Seat Tilt	40
14.14.1	Adjusting Seat Tilt: Operating Instructions.....	40
14.14.2	Tilt Limit	40
14.15	Gas Strut and Cable Assembly	41
14.15.1	Adjusting Cable Tension	41
14.15.2	Removing and Installing the Tilt Cable	41
14.16	Headrest (Optional)	42
14.17	Postural Support Devices or Lap Belts (Optional).....	42
14.18	Oxygen (O2) Tank Holder (Optional)	43
14.19	IV (Intravenous) Pole Mount (Optional)	43
14.20	Take-Apart Frame (Optional)	44
14.21	Motor Vehicle and Transit Use	46
15	ISO 7176-15 TEST INFORMATION DISCLOSURE.....	48
16	LIMITED WARRANTY	50
17	EUROPEAN UNION MDR INFORMATION.....	51

3 NOTICE – READ BEFORE USE

As a manufacturer of wheelchairs, PDG endeavors to supply a wide variety of wheelchairs to meet the many needs of the end user. However, final selections of the type of wheelchair to be used by an individual rest solely with the user and his/her healthcare professional capable of making such a selection. Thus, it is recommended an Assistive Technology Professional, clinical professional or therapist be consulted to determine which model would best meet the wheelchair user's mobility and positioning needs.

All wheelchair set-up and adjustments must be performed by a qualified technician. The options you choose, the set-up and adjustments have a direct impact on the wheelchair's stability. Factors to consider that affect your safety and stability are:

- a. User's abilities and capabilities specifically of strength, balance and coordination.
- b. The types of daily hazards and obstacles encountered.
- c. The specific dimensions, options and set up of the wheelchair. Any changes to the seat height, seat depth, seat angle, back angle, size and position of the rear wheels and front casters will change the stability of your wheelchair. You should only make changes after consulting with a qualified professional.

WARNING and CAUTION notices as used in this manual apply to hazards or unsafe practices, which could result in personal injury or property damage.

NOTE – THE INFORMATION CONTAINED IN THIS DOCUMENT IS SUBJECT TO CHANGE WITHOUT NOTICE. An updated version of this owner's manual may be available at www.PDGMobility.com

INDICATIONS FOR USE – The Fuze T50 Manual Tilt Wheelchair is intended to provide mobility to persons restricted to a seated position.

CONTRAINDICATIONS:

- ◆ Does not have the required ability to adequately manage the functions of a manual tilt-in-space wheelchair and does not have a capable caregiver for the required assistance
- ◆ Cannot tolerate prolonged periods in a seated position with posterior tilt
- ◆ Highly agitated occupants

WHEELCHAIR TIE-DOWN RESTRAINTS AND SEAT RESTRAINTS – PDG does not recommend wheelchair users be transported in vehicles of any kind while in wheelchairs. Wheelchair users should transfer to the vehicle seat and use the vehicle-manufacturer-installed restraint systems whenever it is feasible, and the unoccupied wheelchair should be stored in a cargo area or secured in the vehicle during travel. However, if transportation in a vehicle in the wheelchair is required, the wheelchair must be equipped with PDG factory installed transport-ready tiedown mounting points and the wheelchair occupant must use a restraint device. The Fuze T50 wheelchair complies with the crash testing requirements of ISO 7176-19: 2008 and, as such, has been designed and tested for use as a forward-facing seat in motor vehicle. Thus, for transportation in a vehicle the wheelchair must be restrained from movement using RESNA WC-4:2017, section 18 wheelchair tie-down system and the vehicle must be equipped with RESNA WC-4:2017, section 19 anchor points.

POSITIONING STRAPS and SEAT BELTS - IT IS THE OBLIGATION OF THE HOME DEALER, THERAPISTS AND OTHER HEALTH CARE PROFESSIONALS TO DETERMINE IF A POSITIONING DEVICE IS REQUIRED TO ENSURE THE SAFE OPERATION OF THIS EQUIPMENT BY THE USER. SERIOUS INJURY CAN OCCUR IN THE EVENT OF A FALL FROM A WHEELCHAIR.

4 SAFETY SUMMARY

Operating Information Warning

Unless otherwise noted, all service and adjustments should be performed while the wheelchair is unoccupied.

To determine and establish safety limits, practice bending, reaching and transferring activities in several combinations in the presence of a qualified health professional BEFORE attempting active use of the wheelchair.

- ◆ The necessary back angle **MUST** be selected BEFORE repositioning the rear wheels forward.
- ◆ **DO NOT** operate the tilt function if the trigger release levers and cables are not properly adjusted. Ensure that the tilt function is locked in place when the trigger is released.
- ◆ **DO NOT** traverse, climb or go down ramps or slopes greater than 9°.
- ◆ **DO NOT** leave the occupied wheelchair unattended at any time, especially on an incline.
- ◆ **DO NOT** attempt to reach objects if you must move forward in the seat.
- ◆ **DO NOT** attempt to reach objects if you must pick them up from the floor by reaching down between your knees.
- ◆ **DO NOT** lean over the top of the back upholstery to reach objects from behind as this may cause the wheelchair to tip.
- ◆ **DO NOT** shift weight or sitting position toward the direction of reach as the wheelchair may tip.
- ◆ **DO NOT** tip the wheelchair about the rear wheel without assistance.
- ◆ **DO NOT** use an escalator to move a wheelchair between floors. Serious bodily injury may occur.
- ◆ **DO NOT** attempt to stop a moving wheelchair with the wheel locks. **WHEEL LOCKS ARE NOT BRAKES.**
- ◆ Before attempting to transfer in or out of wheelchair, every precaution should be taken to reduce the transfer gap distance. Turn both casters towards the object you are transferring onto. When transferring to and from the wheelchair, **ALWAYS ENGAGE BOTH WHEEL LOCKS.**
- ◆ **DO NOT** operate the wheelchair on roads, streets or highways.
- ◆ **DO NOT** attempt to move up or down an incline that is wet, icy or is covered in an oily film.
- ◆ **DO NOT** attempt to ride over curbs or obstacles. Doing so may cause your wheelchair to tip and cause bodily harm or damage to the wheelchair.
- ◆ **DO NOT** use unauthorized parts, accessories, or adapters other than those authorized by PDG.
- ◆ **DO NOT** attempt to lift the wheelchair by any removable (detachable) parts.
- ◆ **DO NOT** stand or use feet to apply significant pressure on the frame of the wheelchair.

- ◆ For products supplied with anti-tippers, anti-tippers must be attached at all times.
- ◆ **DO NOT** use the footplate as a platform when getting in or out of the wheelchair.
- ◆ Use positioning devices as recommended by home dealers, therapists, and other healthcare professionals.
- ◆ Positioning belts should be considered to meet the user's specific safety requirements.

Tire Pressure

- ◆ If pneumatic tires are supplied, **DO NOT** use your wheelchair unless it has the proper tire pressure (psi). **DO NOT** over inflate the tires. Failure to follow these suggestions may cause the tire to explode and cause bodily harm. Recommended tire pressure is listed on the side wall of the tire.

Weight Training

- ◆ **PDG DOES NOT** recommend the use of this wheelchair as a weight training apparatus. PDG wheelchairs have **NOT** been designed or tested as a seat for any kind of weight training. If the occupant uses said wheelchair as a weight training apparatus, PDG shall **NOT** be liable for bodily injury and the warranty will be voided immediately.

Weight Capacity

The Fuze T50 wheelchair has a weight limitation of 300 lbs. for the standard base frame

5 SAFETY AND HANDLING OF WHEELCHAIRS

“Safety and Handling” of the wheelchair requires the close attention of the wheelchair user as well as the assistant. This manual points out the most common procedures and techniques involved in the safe operation and maintenance of the wheelchair. It is important to practice and master these safe techniques in order to comfortably and safely navigate in your environment.

Use this information only as a basic guide. The techniques that are discussed on the following pages have been used successfully by many individuals.

Individual wheelchair users often develop skills to deal with daily living activities that may differ from those described in this manual. PDG recognizes and encourages each individual to try what works best in overcoming architectural obstacles that they may encounter. Techniques in this manual are a starting point for the new wheelchair user and assistant with “safety” as the most important consideration for all.

5.1 Stability and Balance

To assure stability and proper operation of your wheelchair, you must always maintain proper balance. Your wheelchair has been designed to remain upright and stable during normal daily activities as long as you do not move your centre of gravity beyond the boundary of the wheelchair and exceed the balance point.

Virtually all activities which involve movement in the wheelchair influence the systems center of gravity. Anti-tippers **MUST** always be attached. PDG recommends using positioning devices for additional safety while involved in activities that shift your weight.

- ◆ **DO NOT** lean forward out of the wheelchair any further than the length of the armrests. Make sure the casters are pointing in the forward position whenever

you lean forward. This can be achieved by advancing the wheelchair and then reversing it in a straight line.

- ◆ **PDG DOES NOT** recommend the use of this wheelchair for stretching exercises. If the occupant uses the wheelchair as a stretching exercise apparatus, keep in mind this will result in changes to the normal balance, the center of gravity and the weight distribution of the wheelchair and make sure stability and balance are not compromised.

Coping with Everyday Obstacles

Coping with the irritation of everyday obstacles can be alleviated somewhat by learning how to manage your wheelchair. Always keep in mind the position of your center of gravity to maintain stability and balance.

- ◆ **WARNING: DO NOT** attempt to perform a “wheelie” in your wheelchair because of the dangerous nature of this type of maneuver.

A Note to Wheelchair Assistants

When assistance to the wheelchair user is required, remember to use good body mechanics. Keep your back straight and bend your knees whenever tilting the wheelchair or traversing curbs, or other obstacles.

Be aware of any removable (detachable) parts. These must NEVER be used for hand-held or lifting supports, as they may be inadvertently released, resulting in possible injury to the user and/or assistant(s)

When learning a new technique, have an experienced assistant help before attempting it alone.

5.2 Tilting

- ◆ **WARNING: DO NOT** tilt the wheelchair without assistance.
- ◆ **WARNING:** Decreased stability may result from a seat position tilted past 0° (neutral) or horizontal. Ensure that anti-tippers are used at all times.

When tilting the wheelchair, an assistant should grasp the back of the wheelchair on a non-removable (non-detachable) part. Inform the wheelchair occupant before tilting the wheelchair and remind him/her to lean back. Be sure the occupant’s feet and hands are clear of all wheels and pinch points. In preparation to operate the tilt:

- Ensure the occupant’s arms and legs are stable on the armrest and the footrest/legrest respectively.
- Ensure the tilt mechanism is clear of hands, feet or foreign objects.
- **DO NOT** push or propel the chair with the seat tilted in a forward position.
- **DO NOT** add chair accessories that are not specifically designed for the Fuze T50.

5.3 Curbs and Steps

- ◆ **WARNING:** Maneuvering over curbs and steps can be dangerous.
- ◆ **WARNING: DO NOT** try to climb or descend a curb or step without assistance. It may cause your chair to exceed its balance point and tip over.
- ◆ **NEVER** attempt to climb or descend a curb or step more than 4” high.
- ◆ **CAUTION: ALWAYS** maneuver straight up and down a curb or step. Climbing or descending at an angle can lead to a fall or tip.
- ◆ **CAUTION:** be aware that dropping down from a curb or step can damage your chair or loosen fasteners.

Use the following procedure to tackle shallow curbs, steps or obstacles:

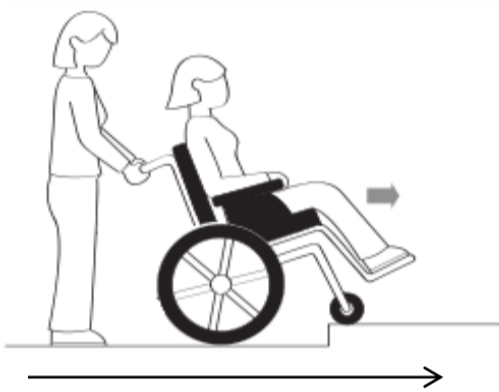

Figure 5.1: Assistant positioning for climbing curbs single steps – method 1

Climbing a curb or single step – Method 1

To climb over a curb or single step have the front of the wheelchair facing the obstacle and advise your assistant to stand at the rear of your wheelchair and apply a continuous downward motion. This will tip the wheelchair about the rear wheels thereby lifting the front caster of the ground. As a balance point is achieved and the front casters clear the curb, instruct your assistance to roll the wheelchair forward and slowly lower the front caster to the upper level as they are beyond the edge of the curb or step. Following, instruct your assistant to lift and roll the rear wheels up to the upper level.



Figure 5.2: Assistant positioning for climbing curbs or single steps- method 2

Climbing a curb or single step – Method 2

Unless the first assistant has exceptional upper body strength, it is recommended that METHOD 2 uses two (2) assistants. The second assistant should be positioned at the front of the wheelchair lifting upward on a non-removable (non-detachable) part of the wheelchair frame when lifting and stabilizing the wheelchair and when the wheelchair is being lowered to the ground. The first assistant should stand on the sidewalk and turn the wheelchair so that the rear wheels are against the curb. The wheelchair should be tilted back to the balance point and, in one continuous downward movement, the rear wheels should be pulled up and over the curb. DO NOT return the front casters to the ground until the wheelchair has been pulled backward far enough for the front casters to clear the edge of the curb.

Descending a curb or single step

WARNING: NEVER attempt to descend down any curb or obstacle facing forward.

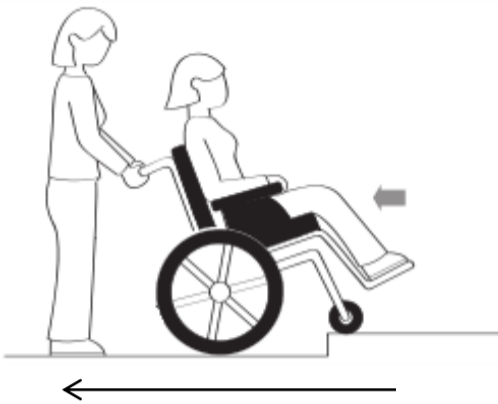

Figure 5.3: Assistant positioning for climbing curbs single steps – method 1

To descend from a curb or a single step, position your wheelchair so that the front of the wheelchair is facing away from the curb a couple of meters and ask your assistant to stand behind your wheelchair. Next, instruct your assistant to step down the curb and carefully pull the wheelchair backwards. As the rear wheels roll over the edge of the curb, allow them to slowly roll down the rear wheels to the lower level. Once the rear wheels are safely on the lower level instruct your assistant to tip the chair about the rear wheels, lifting the casters off the upper level and continue to slowly roll the wheelchair backwards taking small steps until the front casters have cleared the curb or single step and they can be lowered to the ground at the lower level.

5.4 Stairways and Escalators

WARNING – DO NOT use an escalator to move a wheelchair between floors. Serious bodily injury may occur.

WARNING – DO NOT attempt to lift a wheelchair by lifting on any removable (detachable) parts. Lifting by means of any removable (detachable) parts of a wheelchair may result in injury to the user or damage to the wheelchair.

Extreme caution is advised when it is necessary to move an occupied wheelchair up or down the stairs. PDG recommends using two (2) assistants and making thorough preparations. Make sure to use ONLY secure, non-detachable parts for hand-held supports.

Follow this procedure for moving the wheelchair between floors when an elevator is NOT available:



Figure 5.4: Assistant positioning for climbing stairs

1. After the wheelchair has been tipped back to the balance point, one assistant (in the rear) backs the wheelchair up against the first step, while securely grasping a non-removable (non-detachable) part of the wheelchair for leverage.
2. The second assistant, with a firm hold on a non-detachable part of the framework, lifts the wheelchair up and over the stair and steadies the wheelchair as the first assistant places one (1) foot on the next stair and repeats STEP 1.
3. The wheelchair should not be lowered and released until the last stair has been negotiated and the wheelchair has been rolled clear of the top of the stairway.

5.5 Transfers to and from Other Seats

WARNING — before attempting to transfer in or out of the wheelchair, every precaution should be taken to reduce transfer gap distance. Turn both casters toward the object you are transferring onto. Ensure the wheel locks are engaged to help prevent wheels from moving.

NOTE — this activity may be performed independently provided you have adequate mobility and upper body strength.



Figure 5.5: Transferring to and from other seats

1. Position the wheelchair as close as possible alongside the seat to which you are transferring, with the front casters pointing toward it. Engage wheel locks. Shift body weight into seat as you transfer.
2. During independent transfer, little or no seat platform will be beneath you. Use a transfer board if at all possible.

5.6 Weight Distribution

WARNING – DO NOT attempt to reach objects if you have to move forward in the seat or pick them up from the floor by reaching down between your knees.

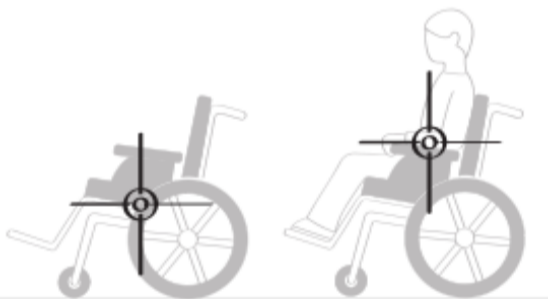

Figure 5.6: Center of gravity location

Many activities require the wheelchair owner to reach, bend and transfer in and out of the wheelchair. These movements will cause a change to the normal balance, the center of gravity, and the weight distribution of the wheelchair. To determine and establish your particular safety limits, practice bending, reaching and transferring activities in several combinations in the presence of a qualified health professional BEFORE attempting active use of the wheelchair.

5.7 Reaching, Leaning, and Bending Forward

Functional Reach from a Wheelchair

Proper positioning is essential for your safety. When reaching, leaning, bending forward, it is important to use the front casters as a tool to maintain stability and balance.

Bending Forward

Position the front casters so that they are extended as far forward as possible and engage wheel locks. **DO NOT LEAN FORWARD OF THE ARMRESTS.**



Figure 5.7: Forward reach in wheelchair

Bending Backward

WARNING — DO NOT lean over the top of the back upholstery. This will change your center of gravity and may cause you to tip over.



Reaching Objects on Ground

Position wheelchair as close as possible to the desired object. Point front casters forward to create the longest possible wheelbase. Reach back only as far as your arm will extend without changing your sitting position.

Figure 5.8: Reaching objects on the ground

6 ENVIRONMENTAL CONDITIONS

WARNING:

1. Use extra care if you must operate your wheelchair on a wet or slick surface. If you are in doubt, ask for help.
2. Contact with water or excess moisture may cause your chair to rust or corrode, resulting in failure of critical components.
 - a. Do not use your chair in a shower, pool or other body of water. The chair tubing and parts are NOT water-tight and may rust or corrode from the inside.
 - b. Avoid excess moisture (for example, do not leave your chair in a damp bathroom while taking a shower or store it outside).
 - c. If your chair does get wet (from cleaning or otherwise), dry it as soon as possible.
3. Terrain
 - a. Your wheelchair is designed for use on firm, regular, even surfaces such as typical interior spaces, concrete or asphalt.
 - b. Operating your wheelchair in sand, loose soil or over rough terrain may damage wheels, casters, the footrests, or other components of your wheelchair.

NOTE - Failure to heed these warnings could result in severe injury to yourself or others as well or damage to your wheelchair.

7 STANDARD FEATURES

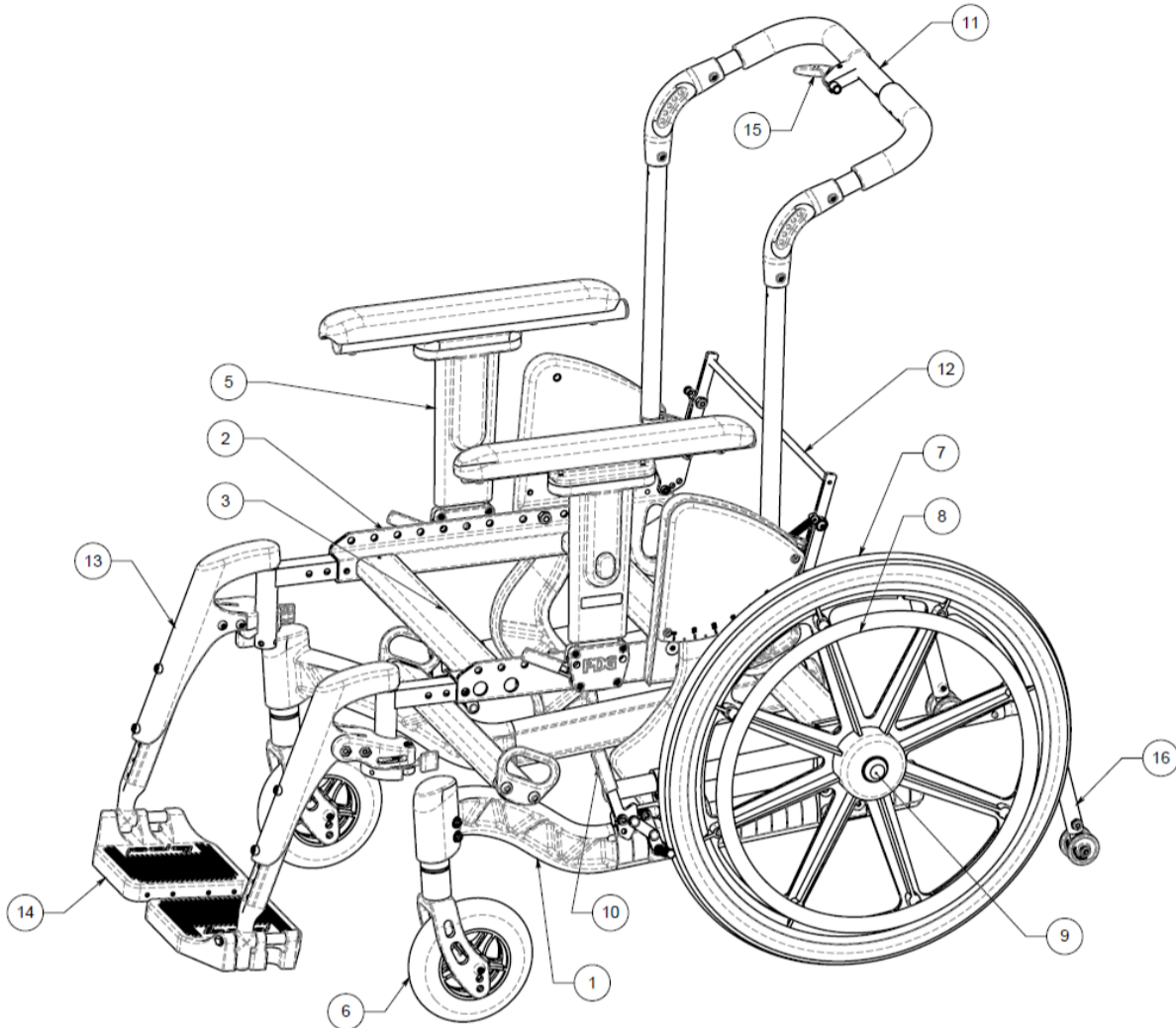

Figure 7.1: Standard Features

- | | |
|--|---------------------------------|
| 1 Lower Frame | 9 Rear Axle Bolt |
| 2 Upper Seat Frame | 10 Wheel locks |
| 3 Cross bar | 11 Back post |
| 4 Tilt Locking System | 12 Fold down back |
| 5 Removable – Adjustable Height
Armrest – Single Post | 13 Swing-Away 70° Front Rigging |
| 6 Front Caster | 14 Composite Foot Plate |
| 7 Rear Wheel | 15 Tilt Activator (Trigger) |
| 8 Standard Hand Rims | 16 Rear Anti-Tipper |

8 UNPACKING AND ASSEMBLY

NOTE – Unless the wheelchair is to be assembled immediately, retain cartons and packing materials for use in storing the wheelchair until assembly is required

1. Check for any obvious damage to the carton or its contents. If damage is evident, take pictures of the damages and notify your Dealer/Carrier immediately.
2. Remove all loose packing from the carton.
3. Carefully remove all components from the carton.

8.1 Inspection

Examine exterior of the wheelchair for nicks, dents, scratches or other damage. Inspect all components. Check the rear wheels for camber. If damage is evident, notify your Dealer/Carrier immediately.

8.2 Out of the Box Assembly Instructions

When unpacking the wheelchair, you will need to assemble the armrests, backrest, and, front rigging (if applicable), connect the cable from the strut to the tilt activator (trigger) and anti-tip tubes to complete the set-up.

Backrest (Deep Seat Depth and Reclining Backrests Only)

The seat frame has two flat head bolts installed along the left and right side of the rear of the seat frame. Remove these bolts on each side and place the backrest subassembly into the back of the seat frame and replace bolts and fasten securely, see section 14.2. To attach tilt actuator cable to the back post (trigger) follow instructions in section 14.15.2

Front Rigging

Installing the front rigging depends on the type of front rigging included with chair – For the Easy-Out front rigging, squeeze the front rigging trigger and slide the front rigging into the square cross-sections on the side of the upper frame until the latch aligns and engages with the upper frame hole and snaps into place. For the standard plug-in front rigging, push in the button on the side of the upper tube and slide into the frame until snap button engages. For the “swing-away” style front rigging attach the front rigging on top of the pre-installed mounted adaptor and rotate to lock into place.

Armrest Assembly

Install the arm assembly by simply sliding the arms into the armrest receivers on the upper frame.

Cable

To install the cable, ensure the lower end of the cable housing is placed in the holes in the junction block and then install the other end of the cable to the trigger, as usual. Once the cable is assembled into the trigger, the assembly will be under slight tension, and the cable housing will stay inserted in the block. Refer to section 14.15 for detailed instructions.

Anti-Tip Tubes

If anti-tip tubes are not already installed on the chair, locate them in the box and slide them into the receivers at the back underside of the frame so that the rollers are pointing downwards. These will prevent the chair from overturning if the centre of gravity moves too far rearward. **Anti-tip tubes are mandatory for safety and warranty protection.**

IMPORTANT — with the user sitting in the chair, check to ensure the wheelchair is stable in all tilted/un-tilted positions before dispensing the wheelchair.

9 STORAGE

Store the repackaged PDG Wheelchair in a dry area away from sunlight and sources of heat. Do not place other objects on top of the repackaged wheelchair.

10 SAFETY INSPECTION CHECKLIST

Examine the exterior of the PDG Wheelchair for nicks, dents, scratches, or other damages. Inspect all components. If damage is evident, notify your Dealer immediately.

NOTE — twice per year take your wheelchair to a qualified dealer for a thorough inspection and servicing. Regular cleaning will reveal loose or worn parts and enhance the smooth operation of your wheelchair. To operate properly and safely, your wheelchair must be cared for in a manner similar to a motor vehicle. Routine maintenance will extend the life and efficiency of your wheelchair.

11 MAINTENANCE

11.1 Cleaning

Periodic cleaning of all surfaces will help maintain the appearance and ensure proper operation of your wheelchair. All surfaces can be cleaned using warm water and a mild soap solution. Do not use abrasive cleaners on any surfaces.

11.2 Suggested Maintenance Procedures

1. Before using your wheelchair, make sure all nuts and bolts are tight. Check all parts for damage or wear and replace them if necessary. Check all parts for proper adjustment.
2. Keep quick-release axles, if fitted, free of dirt and lint to ensure positive locking and proper operation. Refer to ADJUSTING THE QUICK-RELEASE AXLE in section 14.10.2 of this manual.
3. If applicable, oil quick-release axles at least once (1) a month (3-in-1 oil or equivalent).
4. Keep wheel-locks free of dirt to ensure they do not get stuck.

WARNING – If pneumatic tires are used, do not use the wheelchair unless it has the proper tire pressure (psi). DO NOT over inflate the tires. Failure to follow these suggestions may cause the tire to explode and cause bodily harm.

5. If tires are pneumatic, recommended tire pressure is listed on the side wall of the tire.
6. The rear wheels and casters should be checked periodically for cracks and wear and should be replaced when necessary at your authorized dealer or by a qualified technician.
7. For wheelchairs with hand rims, periodically check hand rims to ensure they are secured to the rear wheels.

Initial adjustments should be made to suit your personal body profile and preference. Thereafter the following maintenance schedule is recommended:

ITEM	Initially	Inspect/Adjust Weekly	Inspect/Adjust Monthly	Inspect/Adjust Every 6 Months
GENERAL				
Wheelchair rolls straight (no excessive drag or pull to one side).	x			x
Ensure all fasteners are secure.	x			x
WHEEL LOCKS				
Do not interfere with tires when rolling.	x		x	
Pivot points free of wear and looseness.	x		x	
Wheel locks easy to engage.	x		x	
CLOTHING GUARDS				
Inspect for damage	x			x
Ensure all fasteners are secure.	x			x
SEAT/BACK UPHOLSTERY				
Inspect for rips or sagging.	x			
Ensure all fasteners are secure	x			x
REAR WHEELS				
No excessive side movement or binding when lifted and spun.	x			x
Quick-release axles lock properly and lubricate	x			x
FRONT CASTER				
Inspect wheel/fork assembly for proper tension by spinning caster; caster should come to a gradual stop.	x		x	
Wheel bearings are clean and free of moisture.	x	x		
Ensure caster stem fastener is secure				x
CAUTION: Wheels and tires should be checked periodically for cracks and wear, and should be replaced when necessary.	x		x	
TIRES				
Inspect for flat spots and wear.	x		x	
If pneumatic tires, check for proper inflation	x	x		
Inspect rear tires for cracks and wear.	x			x
CAUTION: Wheels and tires should be checked periodically for cracks and wear, and should be replaced when necessary.	x			
CLEANING				
Clean and wax all parts.				x
Clean upholstery and armrests.				x
Inspect axles are free from dirt, lint, etc.			x	
TILT MECHANISM				
Ensure fasteners are secure and do not show signs of excess wear				x

12 TROUBLESHOOTING

Problems	Solution
<ul style="list-style-type: none"> • Chair veers right • Chair veers left • Sluggish turn or performance • 3 of 4 wheels contacting ground surface 	If pneumatic, check tires for correct/equal pressure
<ul style="list-style-type: none"> • Sluggish turn or performance • Casters flutter • Squeaks and Rattles • Looseness in chair 	Check for loose caster stem nuts and caster axle bolts
<ul style="list-style-type: none"> • Chair veers right • Chair veers left • Sluggish turn or performance • Casters Flutter 	Check caster angle
<ul style="list-style-type: none"> • Chair veers right • Chair veers left • Casters flutter 	Check that both casters contact the ground at the same time
<ul style="list-style-type: none"> • Quick release will not lock and there is excessive play when the wheel hub is being pushed back and forth. 	<p>The nut on the axle needs to be adjusted.</p> <p>The wheel bearing may not be seated properly. This can occur if the bearing have be replaced and may have not been completely seated in the bearings.</p>

13 DAMAGE REQUIRING SERVICE BY QUALIFIED SERVICE AGENT

PDG has trained customer service representatives in many locations. To find your nearest Customer Service Center, contact PDG directly using telephone, fax, or e-mail contact information.

PDG PRODUCT DESIGN GROUP INC.

#103- 318 East Kent Avenue South, Vancouver, BC, Canada. V5X 4N6
 Ph: (604) 323-9220 Fax: (604) 323-9097 e-mail: info@pdgmobility.com

Supply the serial number from the product you are attempting to service and we will be happy to inform you of the supplier who initially provided your product.

In some circumstances it may be required that your wheelchair be returned to a Qualified Service Agent for repairs. If any of the following conditions are observed, the wheelchair must be serviced by a Qualified Service Agent:

- Any part of the frame is cracked or broken
- Any weld is cracked or broken

Always contact your Service Agent prior to sending a wheelchair for repairs. For safe and secure shipping, the wheelchair must be boxed or fastened to a pallet to ensure it does not become damaged during shipping. Service agent will provide specific instructions for packaging and shipping your wheelchair. Alternatively, Qualified Service Agent may arrange for pick-up.

14 SETUP, ADJUSTMENTS & OPTIONS

14.1 Adjustment Guide

The following instructions are intended to help in making wheelchair adjustments. It is important to note the initial wheelchair configuration prior to making changes. When making changes, dealers and users should do so under the guidance of a health care professional who is knowledgeable of the abilities of the wheelchair user. Be sure that when finished, all components are properly tightened and have been completed in accordance with these instructions. DO NOT over tighten hardware attaching to the frame. This could cause damage to the frame tubing or fasteners.

Tools Required

Philips Screw Driver

Allen Key.....	□1/8"	□5/32"	□3/16"	□7/32"	□1/4"
Adjustable or Open End Wrench.....	□7/16"	□3/8"	□1/2"	□3/4"	
Socket Head Driver with Socket Heads.....					□3/4"

14.2 Seat Depth

WARNING – After adjusting, always make sure that parts are properly tightened BEFORE using the wheelchair. The standard seat depth for the T50 can be adjusted on from 15” to 20”, depending on the position of the rear seat depth insert. Custom seat depths from 21” to 22” are also available. They require a Straight Push Bar or Angle/Height Adjustable Push Bar and are not compatible with the Reclining or Fold Down Back. The illustration and table in Figure 14.1 show the seat depth set-up positions and can be referenced for making adjustments.

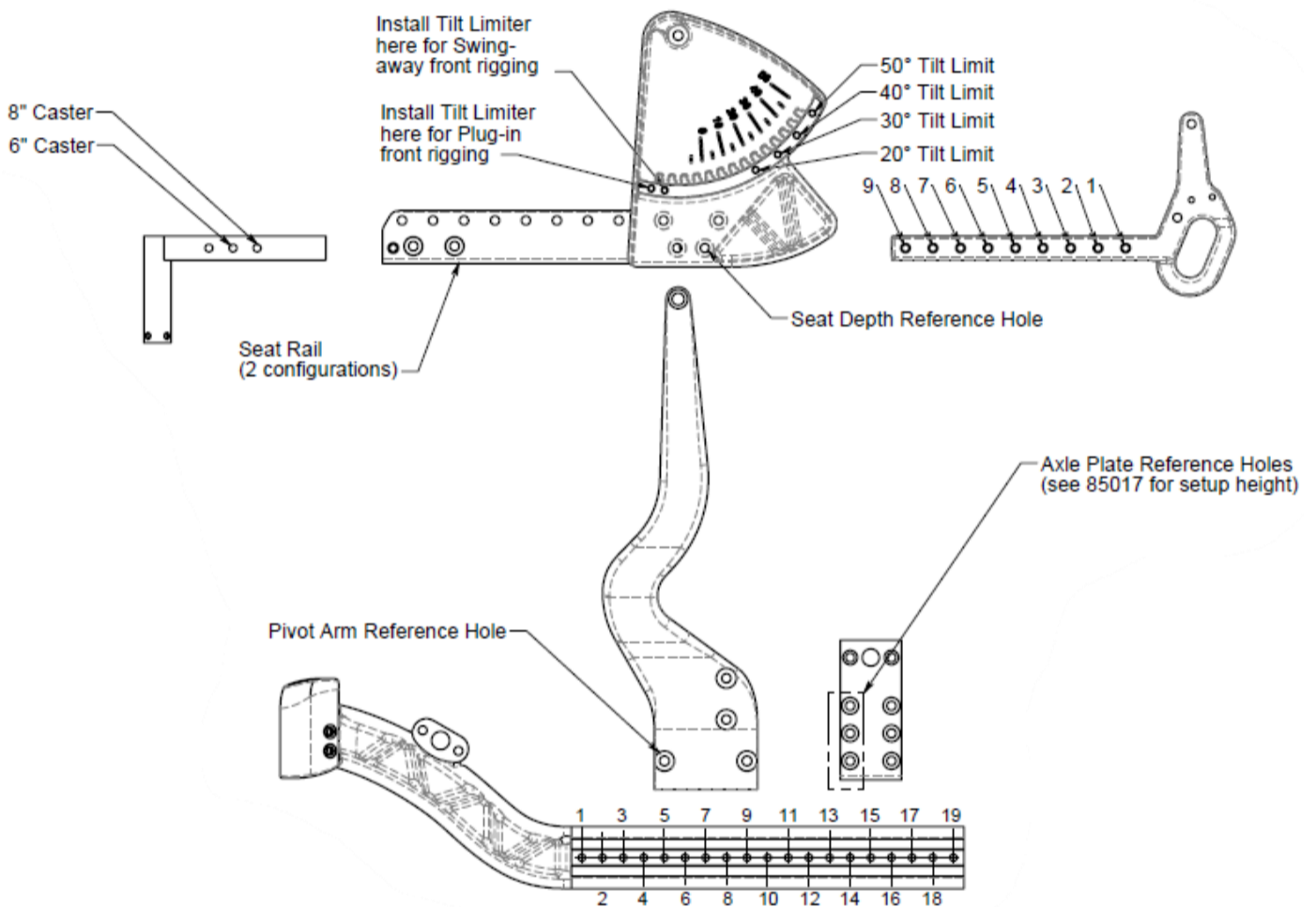

Seat Depth	Seat Depth Position	Seat Rail Configuration	Pivot Arm Location	Axle Plate Position
15"	3	Regular	5	13
16"	4	Regular	5	14
17"	5	Regular	5	14
18"	5	Regular	5	14
19"	5	Long	5	14
20"	5	Long	5	14
21"	5	Long	5	14
22"	5	Long	5	14

Figure 14.1: Seat Depth Positions and Setup

Adjusting the Seat Depth

1. Loosen and remove the two 5/16-18 flat head fasteners on each side (see Figure 14.2).
2. Adjust the rear seat depth insert to the desired position.
3. Retighten the fasteners. Torque to 18 ft. Lbs

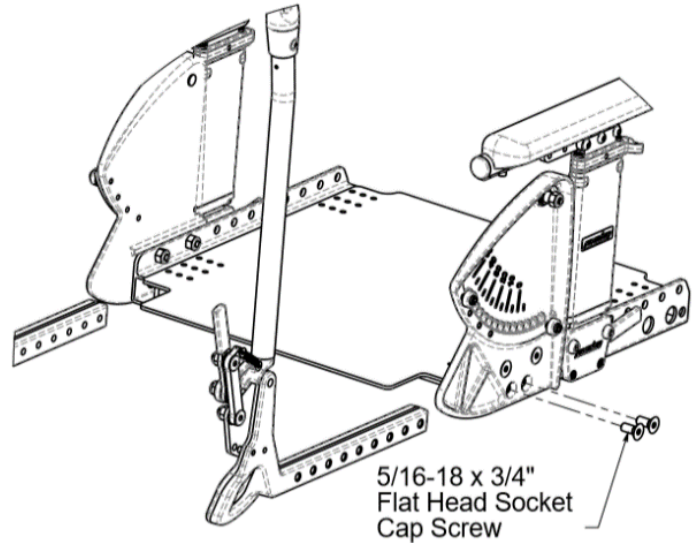

Figure 14.2: Adjusting the seat depth

14.3 Seat-To-Floor Height

WARNING – After making adjustments, always make sure that parts are properly replaced and tightened BEFORE using the wheelchair.

The seat to floor height is measured from the top of the seat pan to the floor. It can be adjusted from 13" to 20" depending on front caster fork assembly and rear wheel combinations.

Adjusting Seat-To-Floor Height

1. Determine the set-up specification of the desired seat to floor height using the detailed axle plate and caster height set-up guides (Figure 14.4 and Figure 14.5).
2. Remove the rear wheels. Adjust the Axle plate position by loosening the 5/16-18(3A) x 1" flat head as shown in Figure 14.3 and adjust the position to the desired location. See Figure 14.4 for axle plate position options.
3. Set the position of the caster journal (available in 3 different sizes) by loosening the 5/16-18 x 7/8" Socket Head Cap Screw. Note the Frame to Journal Setup Distance as shown in Figure 14.5.
4. The caster fork is fitted inside the caster journal. To change the size of the caster fork, the caster journal has to be removed from the lower frame.
5. Set the relative fork caster position to the desired location. See Figure 14.5

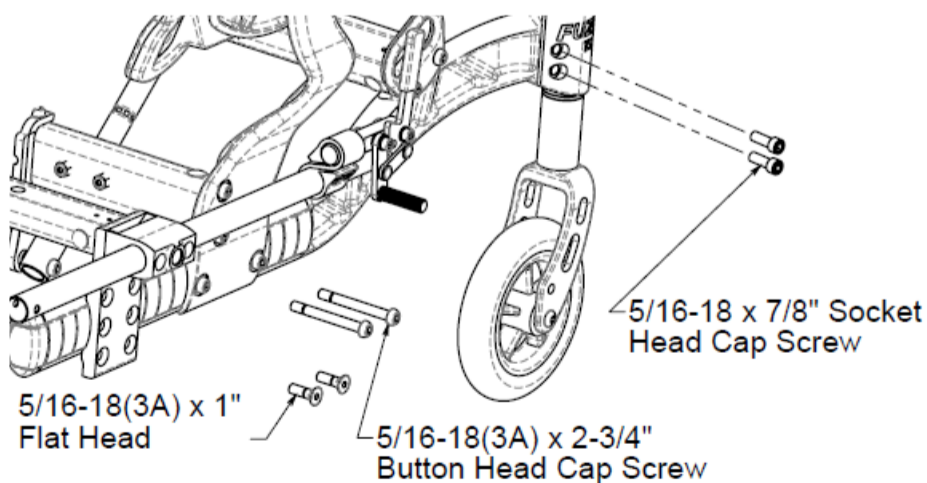
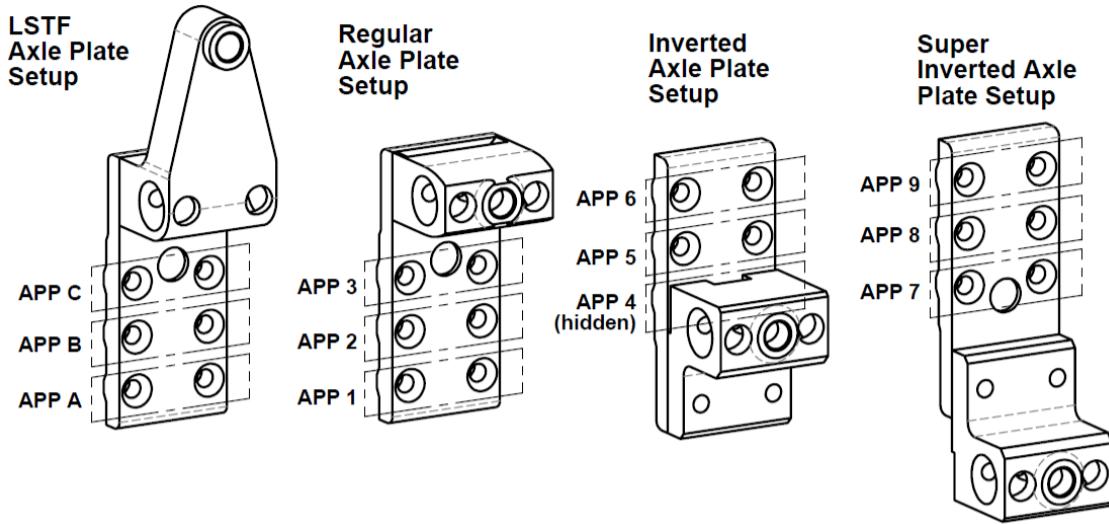

Figure 14.3: The Seat-To-Floor height adjustment fasteners

Figure 14.4: Fuze T50 Axle Plate Set-up Guide



5" Fork/5" Caster									
Axle Plate Position		Seat Height							
		13"	14"	15"	16"	17"	18"	19"	20"
Wheel Size	12"	2	3		4	5			
	16"	C	1	2	3				
	20"	A	C	C	1	2			
	22"		A	B	C	1			
	24"			A	B	C			
6" Fork/6" Caster									
Axle Plate Position		Seat Height							
		13"	14"	15"	16"	17"	18"	19"	20"
Wheel Size	12"		3		4	5	6		
	16"		1	2	3		4		
	20"		C	C	1	2	3		
	22"		A	B	C	1	2		
	24"			A	B	C	1		
8" Fork/6" Caster									
Axle Plate Position		Seat Height							
		13"	14"	15"	16"	17"	18"	19"	20"
Wheel Size	12"				4	5	6	7	
	16"			2	3		4	5	
	20"			C	1	2	3		
	22"			B	C	1	2	3	
	24"			A	B	C	1	2	
8" Fork/8" Caster									
Axle Plate Position		Seat Height							
		13"	14"	15"	16"	17"	18"	19"	20"
Wheel Size	12"				4	5	6	7	8
	16"				3		4	5	6
	20"				1	2	3		4
	22"				C	1	2	3	
	24"				B	C	1	2	3

Figure 14.5: Fuze T50 Caster Height Set-Up Guide:

5" Fork / 5" Caster								
	Seat Height							
	13"	14"	15"	16"	17"	18"	19"	20"
Caster Journal	Small	Small	Medium	Tall	Tall			
Caster Fork Position	1	1	1	1	2			
Setup Distance	0.5"	1.5"	2.5"	3.5"	3.5"			
6" Fork / 6" Caster								
	Seat Height							
	13"	14"	15"	16"	17"	18"	19"	20"
Caster Journal		Small	Small	Medium	Tall	Tall		
Caster Fork Position		1	1	1	1	2		
Setup Distance		0.5"	1.5"	2.5"	3.5"	3.5"		
8" Fork / 6" Caster								
	Seat Height							
	13"	14"	15"	16"	17"	18"	19"	20"
Caster Journal			Small	Small	Medium	Tall	Tall	
Caster Fork Position			1	1	1	1	2	
Setup Distance			0.5"	1.5"	2.5"	3.5"	3.5"	
8" Fork / 8" Caster								
	Seat Height							
	13"	14"	15"	16"	17"	18"	19"	20"
Caster Journal				Small	Small	Medium	Tall	Tall
Caster Fork Position				1	1	1	1	2
Setup Distance				0.375"	1.375"	2.375"	3.375"	3.375"

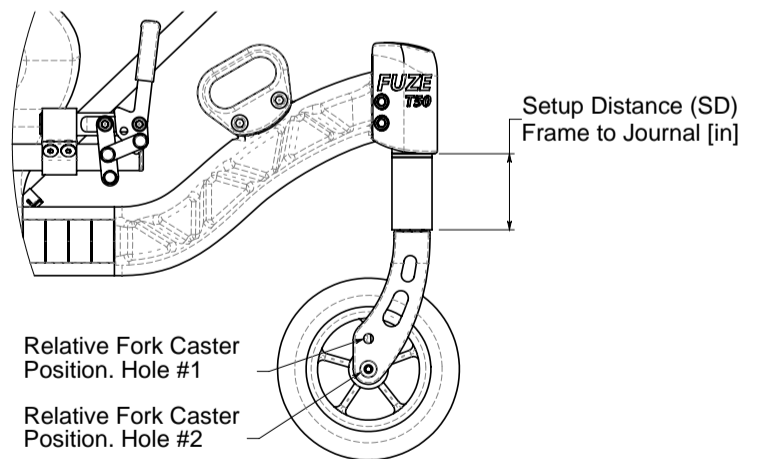
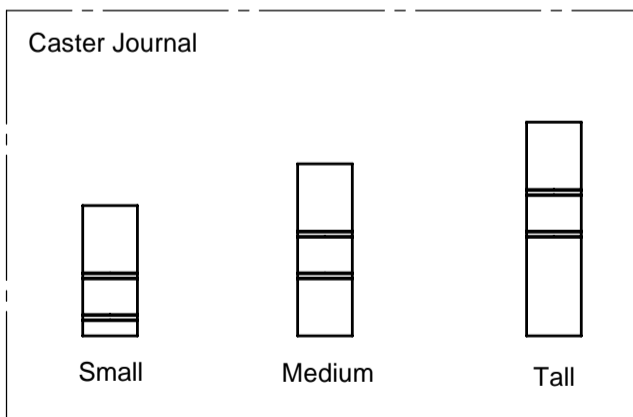

14.4 Armrests

14.4.1 Dual Post Arms

Adjusting Armrest Height

Press the release button on the front tube of the armrest (Refer to Figure 14.6). Adjust armrest to desired height. The armrest height will lock when the release button pops out of the desired armrest height adjustment hole.

Removing Armrests

Release the armrest assembly by depressing the release lever on the front of the armrest (just above the seat pan) while pulling the armrest upwards.

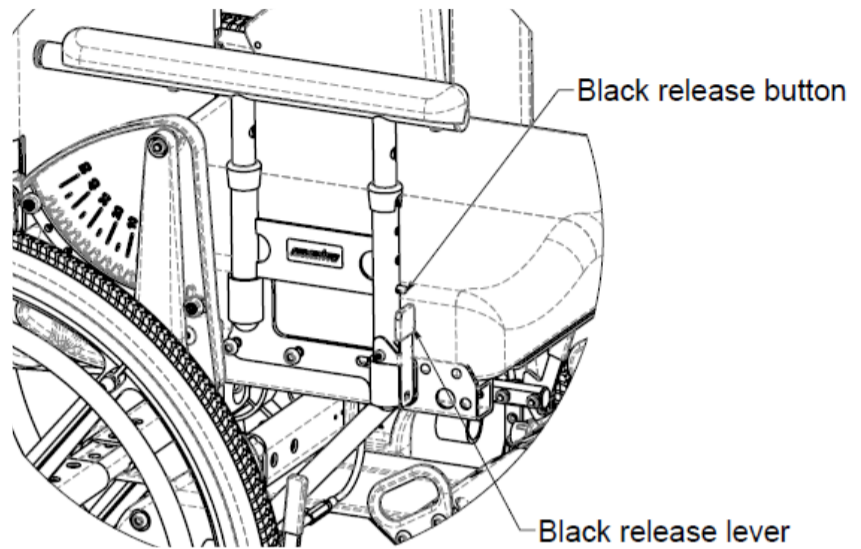

Figure 14.6: Adjusting armrest height for dual post armrests

14.4.2 Single Post Arms

Adjusting Armrest Height

Unlock the armrest by sliding the adjustment on the side of the armrest while moving the armrest up or down (Refer to Figure 14.7). Adjust armrest to desired height. The armrest height will lock when the release button pops out of the side of the armrest.

Removing Armrests

Release the armrest assembly by lifting up on the release lever of the armrest receiver mounted to the seat frame while pulling the armrest up.

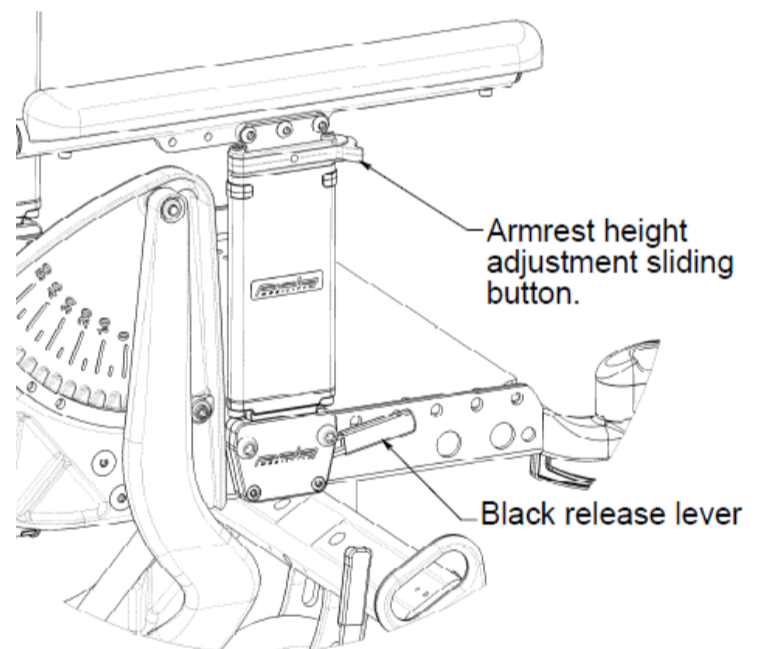

Figure 14.7: Adjusting armrest height for single post arm

14.4.3 Locking Flip-up Armrest

Adjusting Armrest Angle

Armrest angle can be adjusted either up or down by repositioning the “Armrest angle adjustment bolt” (see Figure 14.8) along the array of holes located to the rear of the armrest.

Adjusting Armrest Depth

Armrest depth can be adjusted by removing the “Armrest depth adjustment bolt” (see Figure 14.8) and sliding the armrest forward or rearward to the desired position. The “Armrest adjustment bolt” is then fastened back into place using a Phillips head driver.

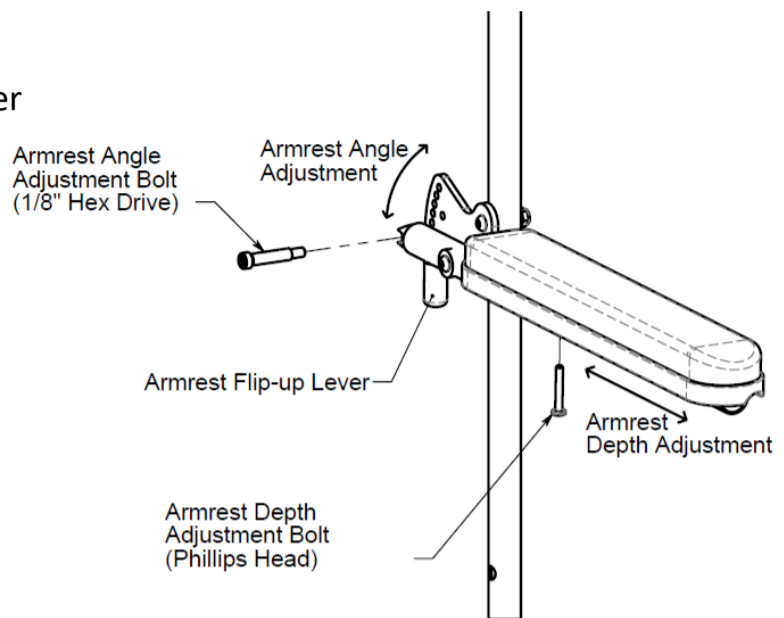

Figure 14.8: Adjustments for locking flip-up armrest

Flipping Armrests Back

Release the locking mechanism of the armrest by sliding the flip-up lever forward (see Figure 14.8). Then rotate the armrest upwards until it clears the backrest. To reset the armrest into the downward locked position, simply rotate the armrest downward until the flip-up lever locks into place.

14.4.4 Armrest Pads

Check for rips or breaks. If these are present, replace immediately to maintain appearance and comfort. If the pad is cracked or retaining screws are stripped, replace immediately.

14.5 Front Rigging

WARNINGS

- ◆ After adjustments, always ensure that parts are properly replaced and tightened BEFORE using the wheelchair.
- ◆ **NOTE** – Ensure that the front rigging adjustment does not cause pressure on the legs at the front of the seat cushion. Such a condition could cause injury to the occupant.
- ◆ **WARNING - DO NOT ATTEMPT** to lift chair by the footrests or leg rests. These components are designed to separate from the wheelchair.
- ◆ **FRONT RIGGING SHOULD BE REMOVED** when entering or exiting from the wheelchair.

14.5.1 Standard Front Rigging (Legacy) – Plug-in 70°, Swing-Away (70° and 90°), Swing Away Elevating Legrest (ELR)

Plug-in 70°

Installation and Removal:

1. To mount plug-in style front rigging, push the snap button located near the top of the footrest tube and slide into open square tube (seat rail) at front of chair. Footrest hanger will lock into position when the button ‘pops’ through hole near the front of the seat rail.
2. To release front rigging push the snap button and slide front rigging forward and out of the open square rail tube.

Footrest Height adjustment:

1. Remove the nut, bolt and coved washers and position the footrest assembly to the desired height.
2. Line up mounting hole and the aluminum insert in the footrest tube, reinstall fasteners and tighten securely.
3. Repeat the procedure for the other footrest.

Swing-Away (70° and 90°)

Installation:

1. Orient the footrest at approximately 45° outboard of the wheelchair as shown in Figure 14.10
2. Insert footrest mounting pin into the mounting tube of the hanger.
3. Rotate the footrest inboard until it locks into place. The footplate will be facing inboard when locked in place.
4. Repeat this procedure for the other footrest assembly

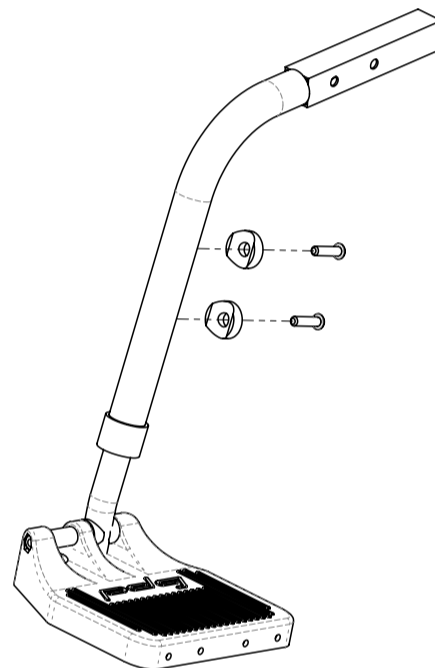

Figure 14.9: Standard plug-in front rigging

Removal:

1. To remove the Swing-Away front rigging, the locking mechanism needs to be released and the front rigging assembly can then be lifted off of the mounting hangers.
2. To release the locking mechanism, push the release lever as show in Figure 14.10
3. As the lever is pushed, rotate the front rigging outboard and lift the footrest mounting pin out of the mounting receiver.

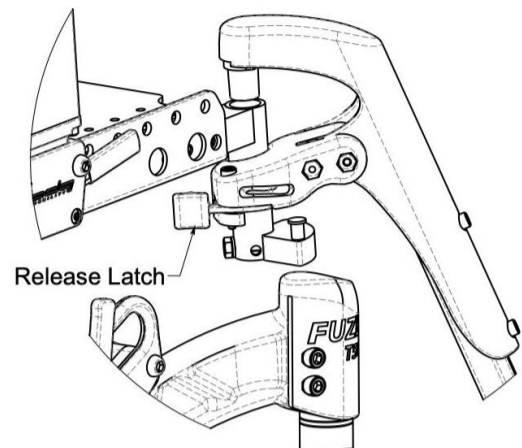

Figure 14.10: Swing-Away Front Rigging Latch Installation and Removal rigging

Footrest Height adjustment

1. Remove any padding and/or calf strap, if fitted. Remove the fastener and nut as shown in Figure 14.11
2. Position the footrest assembly to the desired height and line up the mounting holes.
3. Reinstall the hardware and tighten securely.
4. Repeat this procedure for the other footrest and replace padding and/or calf strap, if fitted.

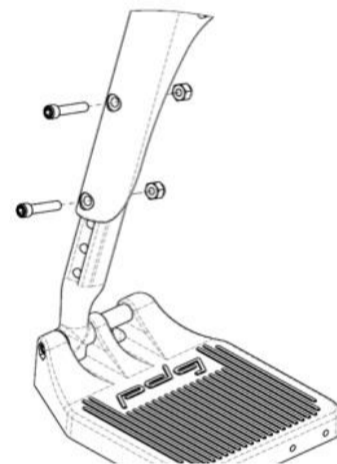

Figure 14.11: Standard Swing-Away footrest height adjustment

Swing Away Elevating Legrest (ELR)

Installation and Removal:

1. The installation and removal of the Elevating Legrest is similar to the Swing-Away Front Rigging. Refer to the instruction for the Swing-Away front rigging.

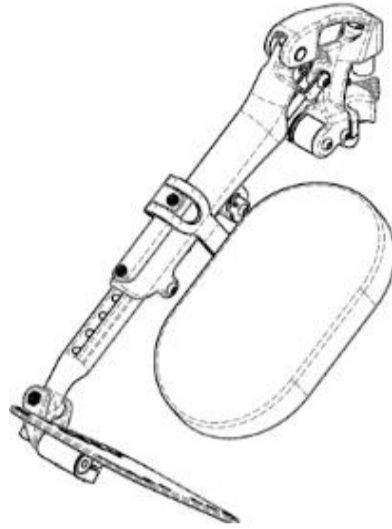

Figure 14.12: Elevating Legrest Footrest Height adjustment

Footrest Height adjustment:

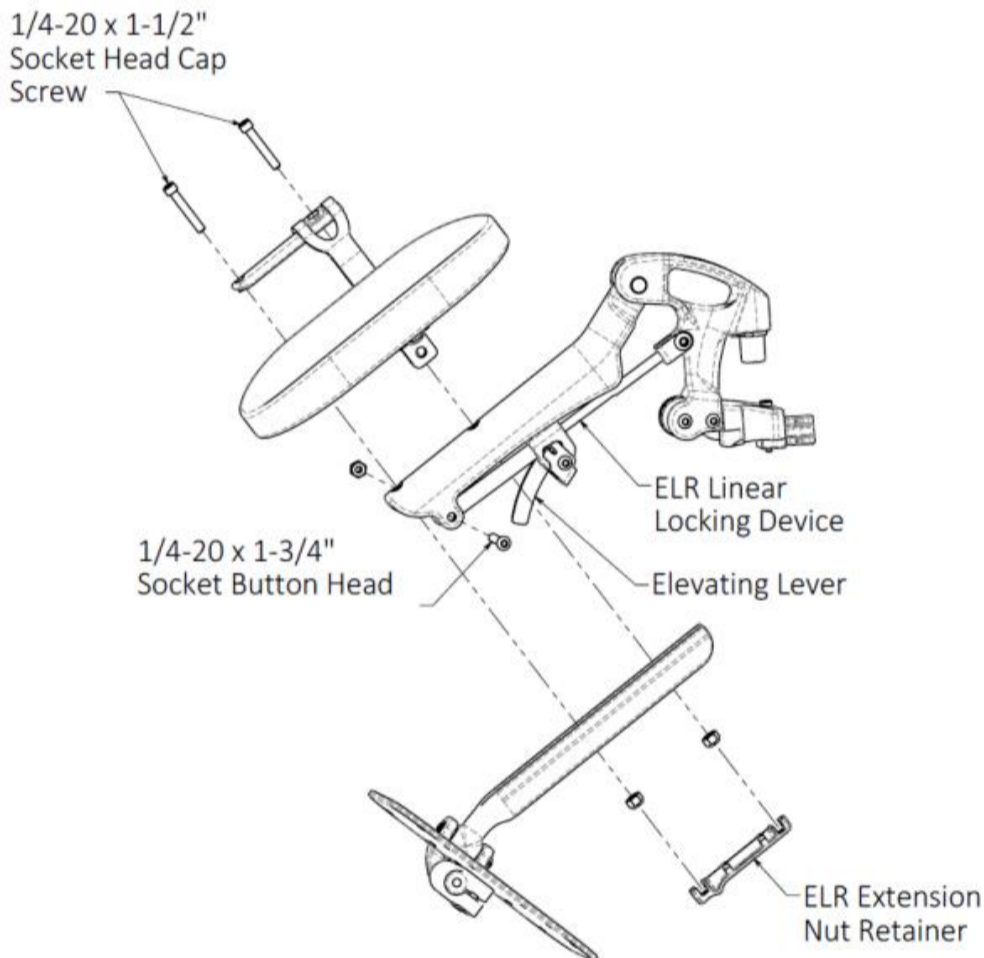

Figure 14.13: Swing-Away Elevating Legrest

1. Loosen and remove the ¼-20 x 1-3/4" Socket Button Head which holds the ELR's linear locking device, shown in Figure 14.12.
2. Adjust the legrest extension to the desired position, line up the mounting holes and re-install and securely tighten the socket head cap screws.
3. Re-install the ¼-20 x 1-3/4" socket button head in the eyelet of the linear locking device and securely tighten
4. Repeat the procedure for the other footrest.

14.5.2 Easy-Out™ Front Rigging Footrest Assembly – Plug-in 70°, Adjustable Knee Angle Front Rigging.

Plug-in 70° Front Rigging Footrest Assembly

Installation and Removal:

1. To mount the easy out plug-in front rigging, depress the lever located under the plug-in and slide the front rigging into the open square tube receiver (upper frame seat rail). The fronting rigging will lock into position when the lever snaps through the hole located on the bottom of the square receiver tube.
2. To release the front rigging similarly, activate the trigger to disengage the lever from the holder and slide the front rigging forward and out of the upper frame.

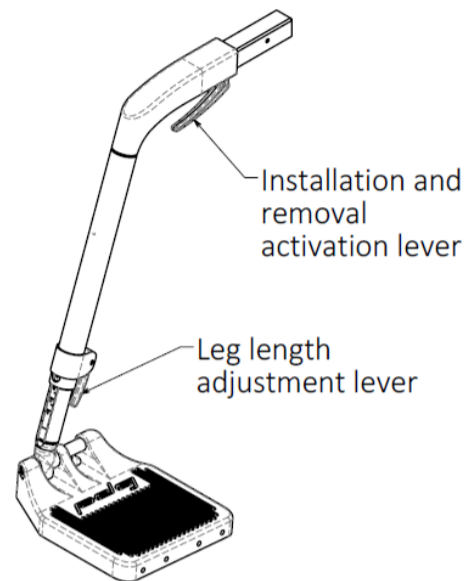

Figure 14.14: Easy-Out Plug-In 70° Front Rigging

Plug-In Adjustable Knee Angle Front Rigging (Optional)

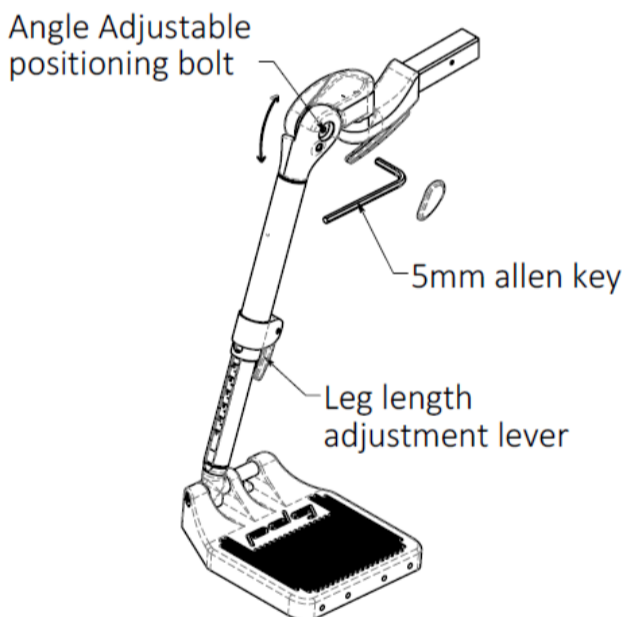

Figure 14.15: Easy-Out Angle Adjustable Front Rigging

Installation and Removal of this option is the same as the Easy-out Plug-in 70 Front Rigging.

To adjust the Knee Angle Front Rigging:

1. Remove the plastic cover on the side by prying it off by hand.
2. Unlock the knee angle joint by loosening the socket head fastener ½ a turn.
3. Adjust the angle of the front rigging to the desired location.
4. Once set to the desired location, re-tighten the socket head fastener and re-install the plastic cover.

Footrest Height adjustment:

1. Release the leg length adjustment lever. This is shown in Figure 14.15.
2. Adjust the footrest extension to the desired height.
3. Fully depress the lever to lock the footrest extension height.

Note: Height adjustment can be performed with the individual sitting in the wheelchair with their feet on the foot plates. The lowest point of the foot plates should be no less than 2" from the ground or floor.

14.6 Footplates

WARNING – Do not flip-up footplate as an alternative to removing the front rigging.

DO NOT ATTEMPT TO STAND ON FOOTPLATES. Standing on the footplates will cause the wheelchair to tip forward abruptly and may result in a serious fall of the individual.

Composite Footplates

The default footplates for the Fuze T50 is the composite footplates. These composite footplates offer flip-up functionality. To flip up the footplate simply pull upwards on the inboard end of the footplate.

Aluminum Angle Adjustable (Optional)

Angle adjustable footplates allow the depth and the angle of the footplate to be adjusted. These angle adjustable footplates also offer flip-up functionality. To flip up the footplate simply pull upwards on the inboard end of the footplate.

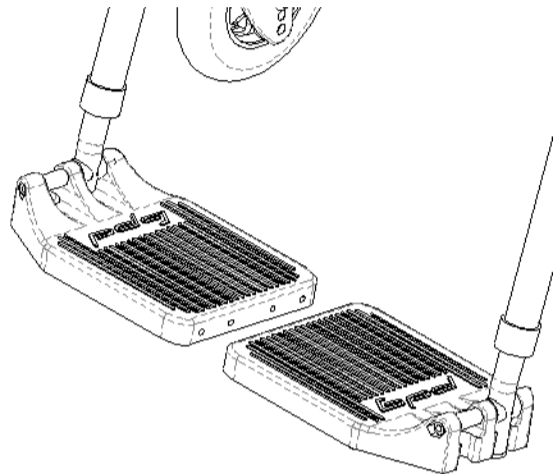

Figure 14.16: Composite Footplates

Adjusting the Footplate Angle

1. Loosen the angle adjustable footplate adjustment bolts as shown in Figure 14.17.
2. Rotate the footplate until it is at the desired angle.
3. Ensure the clamp is fully engaged and tighten the bolts.
4. Repeat for the other footplate if required.

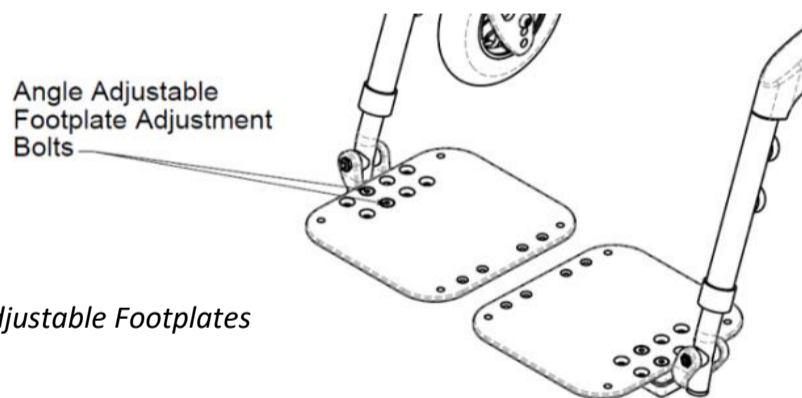

Figure 14.17: Angle Adjustable Footplates

Adjusting the Depth

1. Remove the angle adjustable footplate adjustment bolts as shown in Figure 14.17.
2. Invert the clamp if required and align the footplate with the preferred holes.
3. Reinstall and tighten the nuts and bolts.
4. Repeat for the other footplate if required.

One Piece Footplate (Optional)

One-piece footplates are available in two types: fixed and flip-up (See Figure 14.19 and Figure 14.18). To flip up the one-piece flip-up footplate, simply pull upwards on the footplate.

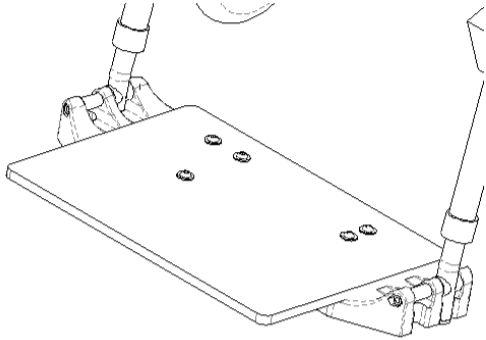

Figure 14.19: Fixed one piece footplate

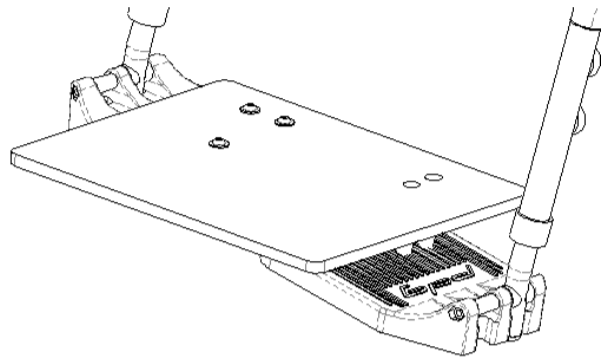

Figure 14.18: Flip-up one piece footplate

Interlocking Angle Adjustable Footplates (Optional)

Angle adjustable interlocking foot plates allow the depth and the angle of the footplate to be adjusted. Additionally, these footplates have flip-up functionality. To flip up the footplate simply pull upwards on the footplate. When these footplates are not flipped up, they are interlocked together. (See Figure 14.20)

NOTE- When adjusting interlocking footplates, ensure they are locked together.

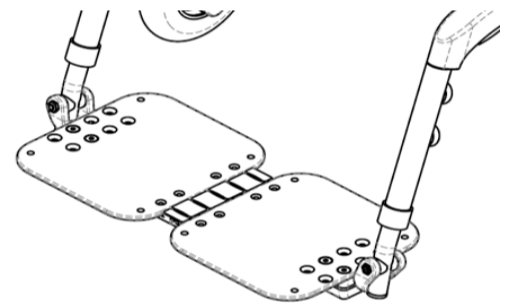

Figure 14.20: Interlocking Adjustable Angle Footplates

Adjusting the Footplate Angle

1. Loosen the angle adjustable footplate adjustment bolts (See Figure 14.17).
2. Rotate the footplates until they are at the desired angle.
3. Reinstall and tighten the bolts.

Adjusting the Depth

1. Remove the angle adjustable footplate adjustment bolts shown (See Figure 14.17).
2. Align the footplates with the preferred holes.
3. Reinstall and tighten the nuts and bolts.

14.7 Heel Loops (Optional)

The heel loops are positioned behind the occupant's heels to prevent the feet slipping backwards. Adjust the hook-and-loop strap to obtain the desired length of strap to correctly position the feet on the footrest.

WARNING - Improper positioning of feet may result in accident or injury. Please consult your dealer for proper strap adjustment.

14.8 Padded Calf Strap (Optional)

The calf strap is positioned behind the occupant's lower calves to prevent the legs and/or feet slipping backwards. Adjust the hook-and-loop strap to obtain the desired length of strap to correctly position the feet on the footrest.

WARNING— improper positioning of feet may result in accident or injury. Please consult your dealer for proper strap adjustment.

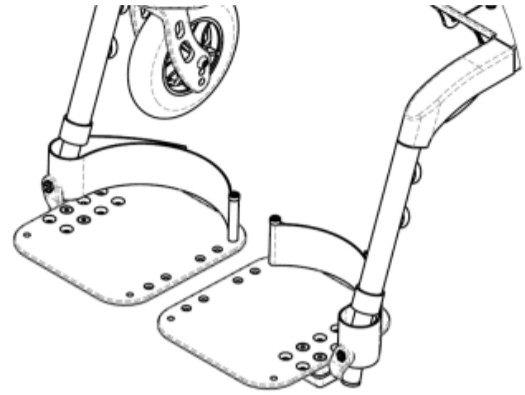

Figure 14.21: Heel loops

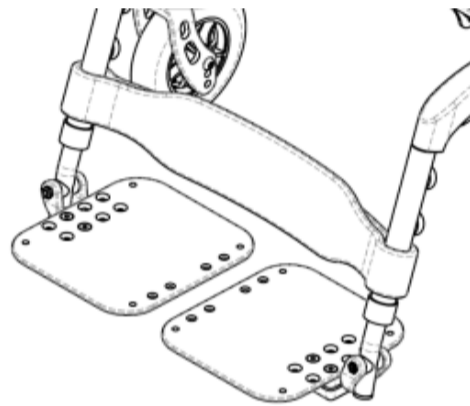

Figure 14.22: Padded calf strap

14.9 Backrest Adjustments and Options

WARNING – After making adjustments, always make sure that parts are properly tightened BEFORE using the wheelchair.

14.9.1 Angle/Height Adjustable Push Bar Handle

The wheelchair may be purchased with an adjustable angle push bar handle. This handle allows an attendant to change the position of the push bar handle grip and even the tilting lever position, depending on the wheelchair’s original configuration.

Adjusting Push Bar Angle

1. To adjust the push bar angle, simultaneously press both plastic push bar buttons located on the top of both backrest posts (see Figure 14.23).
2. While the plastic push bar buttons are depressed, adjust the position of the push bar.
3. When the push bar is positioned to satisfaction, release the plastic push bar buttons and rotate to a locked position.

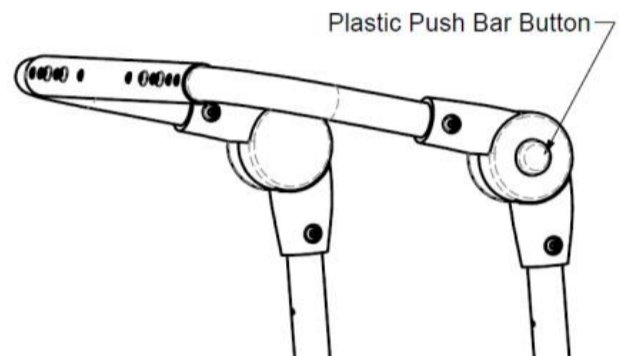

Figure 14.23: Adjustable push bar handle

Adjusting the Seat to Back Angle

WARNING - Ensure the chair is not occupied before adjusting the seat to back angle.

1. The seat-to-back angle may be set at a range of 90° to 122°. Remove ¼-20 cap screw and loosen the pivot bolt.
2. Adjust the bracket to the desired angle and re-install the ¼-20 cap screw. Refer to Figure 14.24 for the cap screw position for different back angles.
3. Ensure the ¼-20 cap screw and pivot bolts are completely tightened.

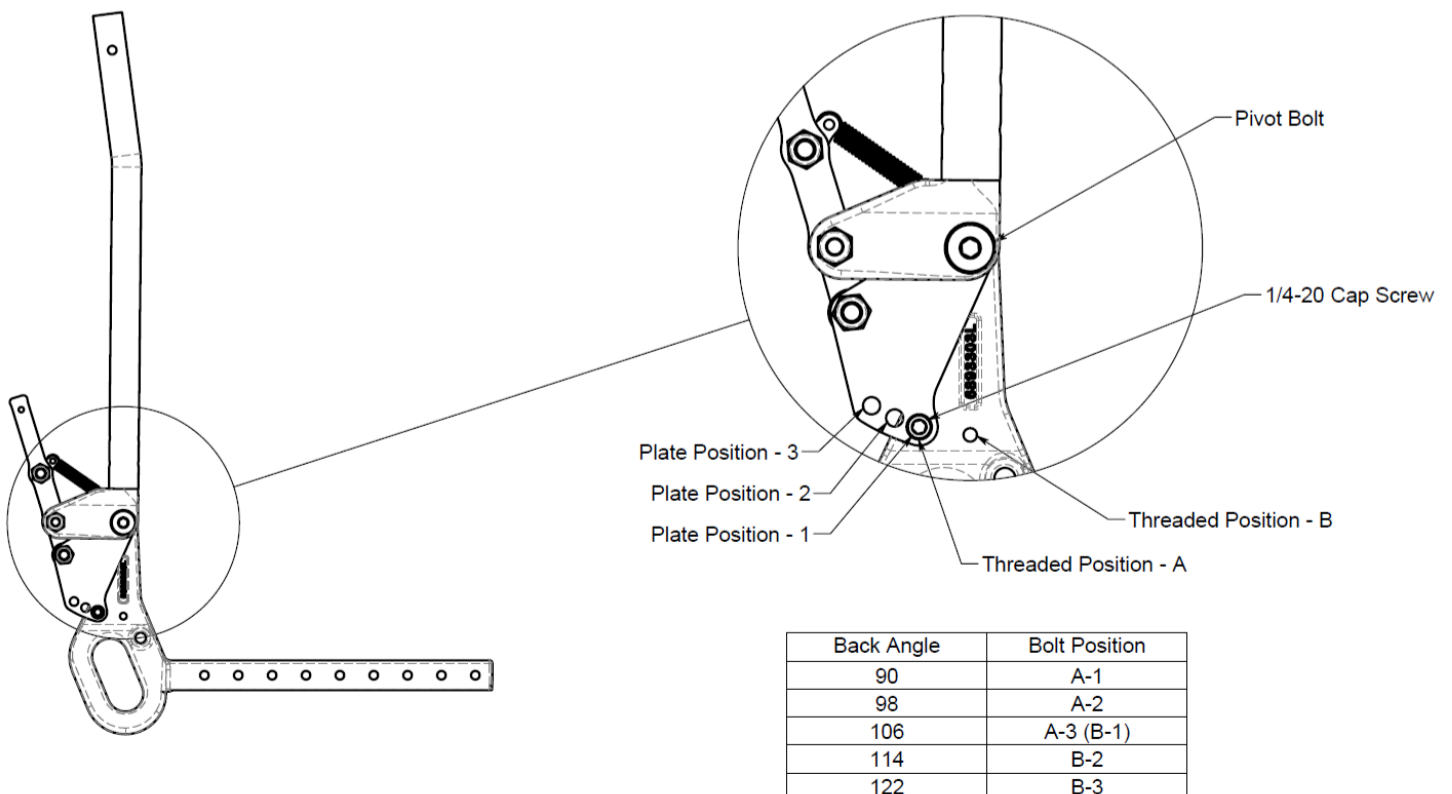

Figure 14.24: Backrest Angle Adjustment

14.9.2 Fold Down Backrest (Not compatible with Reclining Back)

The wheelchair is available with the option of a fold down backrest designed to facilitate chair storage and transport.

To fold down the backrest:

WARNING - Ensure the chair is not occupied before folding down the backrest.

1. Remove the armrests from the armrest receivers (see section 14.4 for instructions).
2. Push the backrest fold-down lever downwards, this should trigger the back posts to move forward and fold-down.
3. To unfold the backrest, simply pull up on push bar and the back posts are guided to the upright position.

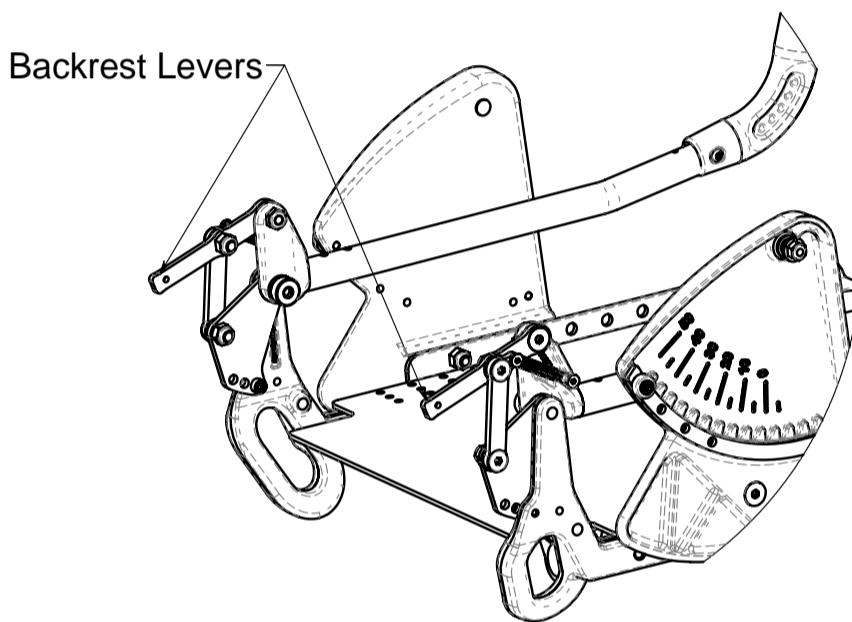

Figure 14.25: Fold-down Backrest

14.9.3 Reclining Backrest (Not compatible with Fold-down backrest)

The Fuze T50 wheelchair is available with the option of a manual reclining backrest that allows for up to 30° of backrest recline. It is not compatible with the Candle Handle Back, Fold Down Back, and not available for higher seat depths of 21" and 22".

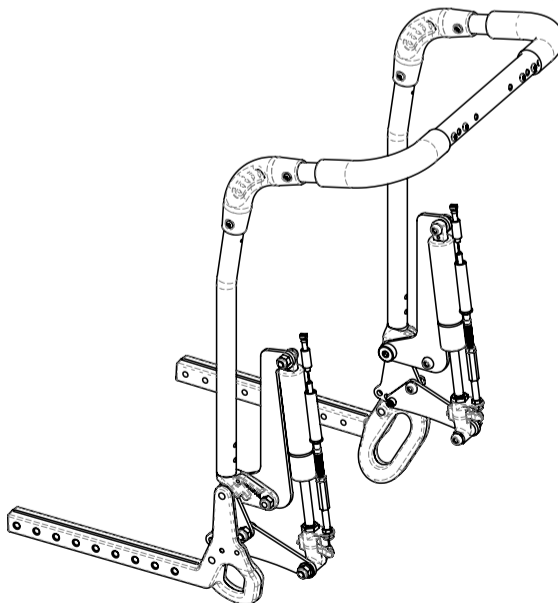

Figure 14.26: Reclining Backrest

14.10 Rear Wheels

14.10.1 Removing/Installing the Rear Wheels/Axles

1. If the wheelchair is fitted with fixed axles, the rear wheels can be removed/installed using a $\frac{3}{4}$ " socket head wrench or equivalent.
2. If quick-release axles have been supplied, push on the quick-release button and it should release the axle pins allowing for the axle and rear wheel to slide out of the axle plate. To reinstall the rear wheels, reverse the step and ensure that the axle pins completely release and lock the rear wheels on to the wheelchair.

WARNING - Make sure the detent and locking pins of the quick-release are fully released BEFORE operating the wheelchair. Keep locking pins clean.

WARNING – Do not use wheelchair UNLESS you are sure both quick-release axles are locked. Ensure you do not inadvertently disengage the quick release. An unlocked axle may come off during use and can cause personal injury.

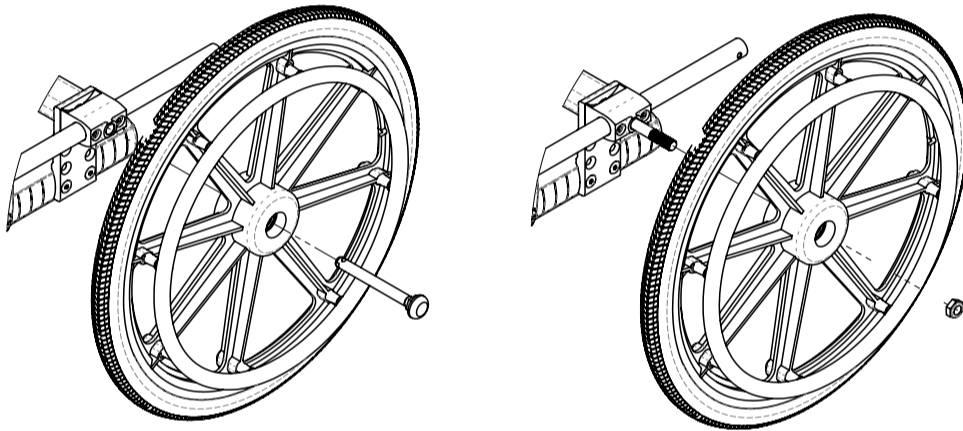

Figure 14.27: Removing rear wheels fastened with axle bolt / Removing rear wheels fastened with quick release axle

14.10.2 Rear Wheel Axle Nut Adjustment (For Quick-Release Axles)

The quick-release axle attaches the rear wheel to the axle receiver. When the axle is fully inserted into both the wheel and axle receiver the detent balls will lock the wheel assembly in place. Pushing the button on the quick-release axle will disengage detent balls to allow the wheel to be removed. If the wheel and axle will not lock or there is excessive play when the wheel hub is being pushed back and forth, the nut on the axle needs to be adjusted.

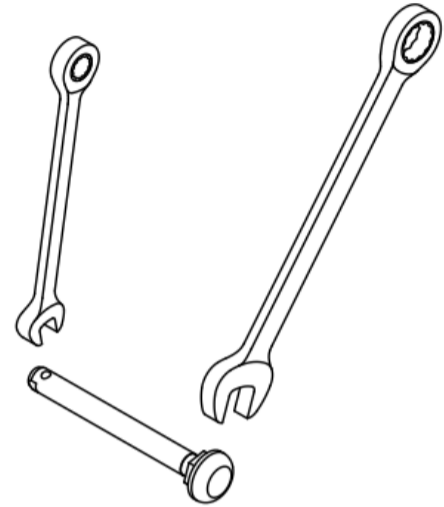

Figure 14.28: Quick release axle adjustment

If the axle does not lock:

1. Using a 7/16" open end wrench, securely hold the detent ball end of the axle. (See Figure 14.28)
2. Use the 3/4" open-wide wrench to turn the axle nut counter-clockwise.
3. Turn the nut in approximately 1/2 turn increments.
4. Try to lock the axle into the axle receiver. The axle is locked when the pin at the ball detent of the axle is flushed with the end of the axle when the button is released.
5. If it does not lock, repeat steps 3 and 4 until it locks securely.

If the axle locks, but there is excessive play:

1. Using a 7/16" open end wrench, securely hold the detent ball end of the axle. (See Figure 7.1 Figure 14.28)
2. Use the 3/4" open-wide wrench to turn the axle nut clockwise.
3. Turn the nut in approximately 1/2 turn increments.
4. Insert the axle and test for play.
5. Repeat steps 3 and 4 until the play has been eliminated and the detent balls are fully extended.

IMPORTANT – With the user sitting in the chair, check to ensure the wheelchair is stable in all tilted/un-tilted positions before dispensing the wheelchair.

14.11 Anti-Tippers

Your wheelchair is provided with anti-tippers designed to prevent the chair from tipping over backward in most normal conditions.

WARNING - Do NOT operate wheelchair without anti-tippers installed. Anti-tippers are mandatory for safety and warranty protection.

To install the anti-tippers:

1. Press and hold the release button on the anti-tipper tube. (See Figure 14.29)
2. Insert the anti-tip tube into the receiver as shown until it locks into position.

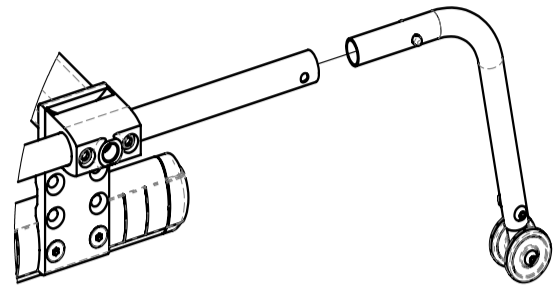

Figure 14.29: Installing anti-tip tubes

Setup of 16"/22"/24" Rear Wheel Anti-tipper Height

The hole position on the anti-tip tube based on rear wheel sizes are shown in Figure 14.30.

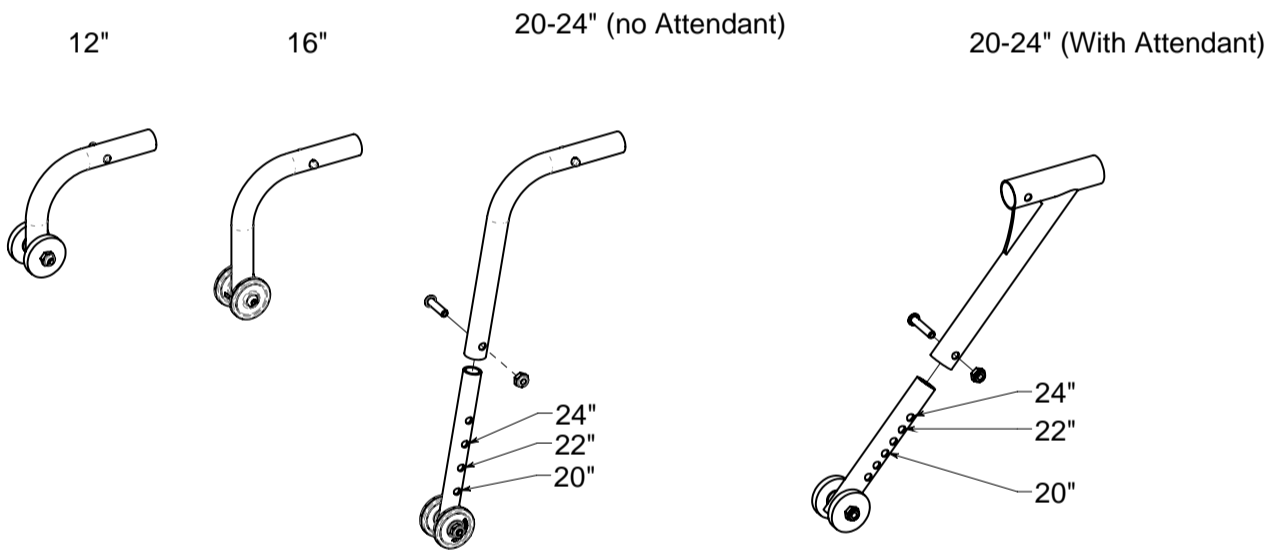

Figure 14.30: Anti-tipper positioning

14.12 Front Casters

WARNING – After making adjustments, always make sure that parts are properly replaced and tightened BEFORE using the wheelchair.

Installing/Replacing Caster Forks

1. Before removing the caster fork assembly, note the position of the caster journal relative to the lower frame for future reference when re-installing.
2. Using a ¼" Allen key, loosen the 5/16-18" socket head shoulder bolt and the caster journal and fork assembly should slide out of the lower frame.
3. Next, loosen the ½"-20 nut on caster stem using a ¾" socket wrench and slide out the caster fork assembly.
4. Reassemble by reversing steps 1-4 (Be sure bearings are replaced if removed).
5. Test the wheelchair for maneuverability.
6. Ensure that the lower frame of the wheelchair is level after performing caster adjustments and that the casters do not interfere with the front rigging.

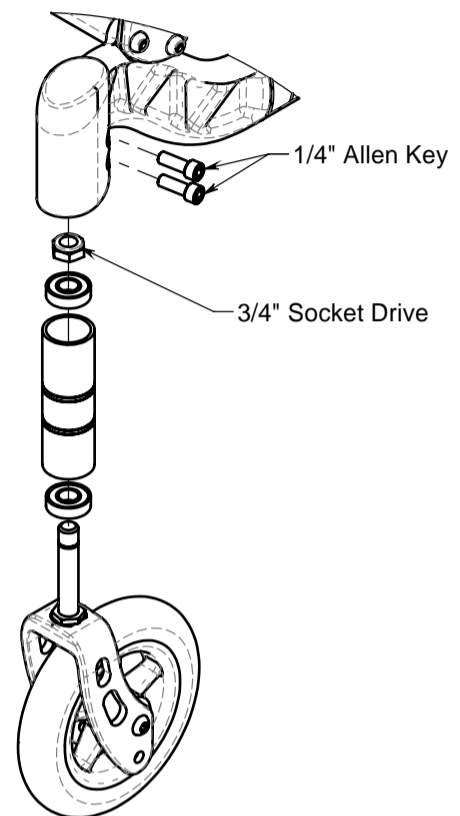

Figure 14.31: Installing/Replace Caster Forks

14.13 Wheel-Locks

WARNING – Never attempt to engage wheel locks while the chair is in motion as it could cause you to lose control.

Wheel locks lock the rear wheels and prevent any undesirable movement of the wheelchair.

1. To engage the push to lock wheel lock (see Figure 14.32), push the lever forward, away from the wheel, until it locks into place.
2. To engage the pull to lock wheel lock (see Figure 14.33), pull the lever towards the wheel until it locks into place.
3. To engage the attendant wheel lock (see Figure 14.34), pull the lever towards the wheel until it locks into place.
4. To engage the attendant wheel lock in the User and Attendant Wheel Lock option (see Figure 14.35), follow the step 3 instructions, follow the instructions corresponding to the user wheel lock type (i.e. Push to Lock or Pull to Lock).
5. To engage the wheel locks with the anti-rollback device, follow the instructions corresponding to the wheel lock type (i.e. Push to Lock or Pull to Lock).
6. To engage and disengage the Foot Operated Wheel Lock, simply push down or flip up the foot lever shown in Figure 14.36.

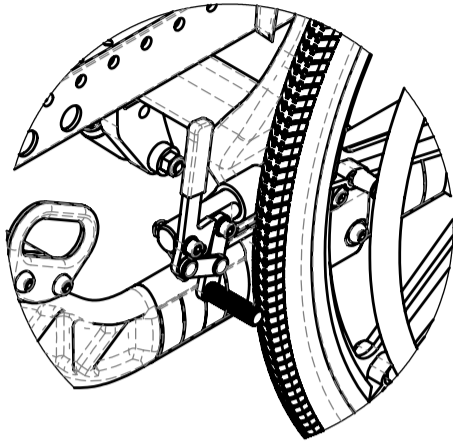

Figure 14.32: Push to Lock Wheel Locks (Standard)

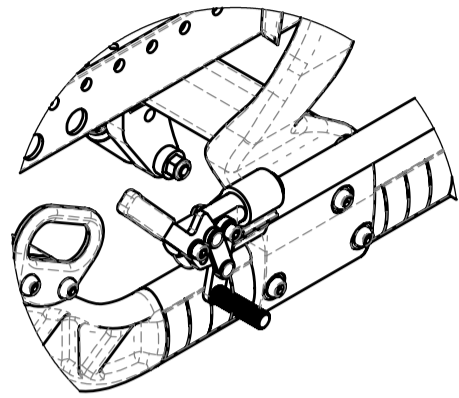

Figure 14.33: Pull to Lock Wheel Locks

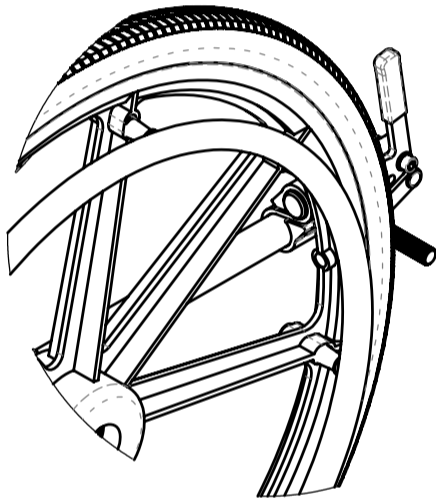

Figure 14.34: Attendant Wheel Lock (Push to Lock)

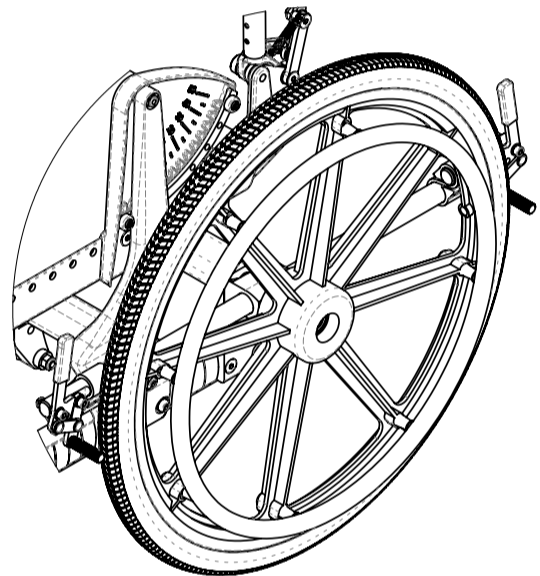

Figure 14.35: User Wheel Locks and Attendant Wheel Locks

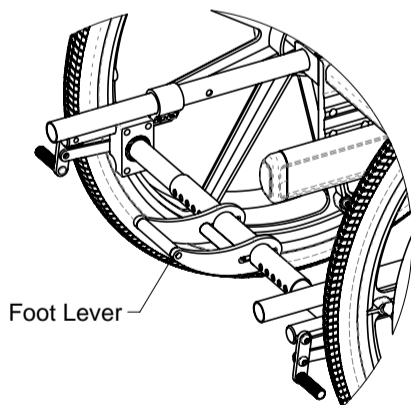

Figure 14.36: Foot Operated Wheel Lock

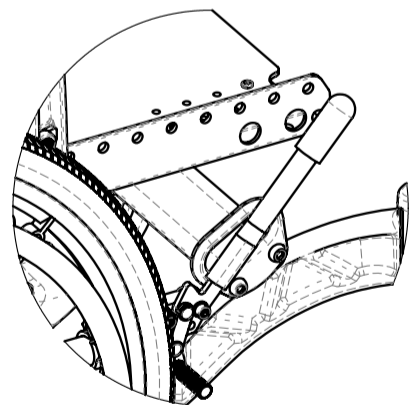

Figure 14.37: Wheel Lock Extension

14.14 Seat Tilt

WARNING – After making adjustments, always make sure that parts are properly replaced and tightened BEFORE using the wheelchair.

14.14.1 Adjusting Seat Tilt: Operating Instructions

The Fuze T50 tilt-in-space feature is designed using a center of gravity tilt. Meaning the occupants center of gravity facilitates in positioning the seat angle. The seat angle is set with the use of a linear mechanical locking device also referred to as a mech-lock, see Figure 14.38 and Figure 14.39. To adjust the tilt angle, activate the tilting lever/trigger located on the push bar, depending on how the wheelchair has been configured. This activation releases the lock on the mech-lock allowing the wheelchair seat to be lowered into and out of tilt. Once the activation lever/trigger is released the seat angle should lock in its position.

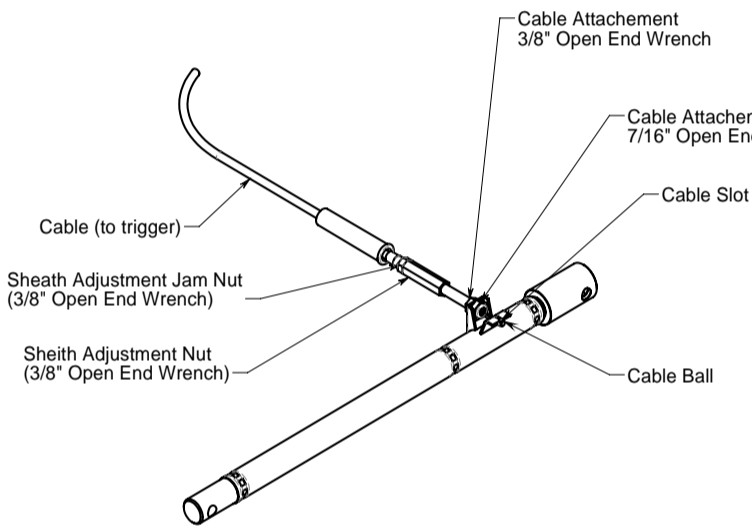

Figure 14.38: T50 Mech. Lock

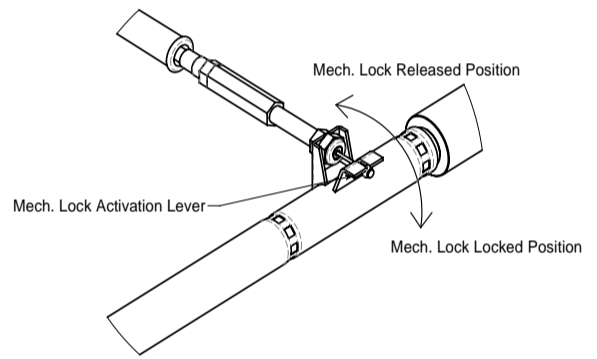

Figure 14.39: T50 Mech. Lock - Locked and released positions

NOTE- Depending on configuration, the tilt lever may be mounted onto the left or right side of the backrest push bar or on the left or right armrest.

WARNING – When tilting chair, attendant must hold the push bar or back canes securely so that seat does not drop too suddenly.

14.14.2 Tilt Limit

The Tilt limit on the Fuze T50 is set on the side of the upper frame as show below in Figure 14.40.

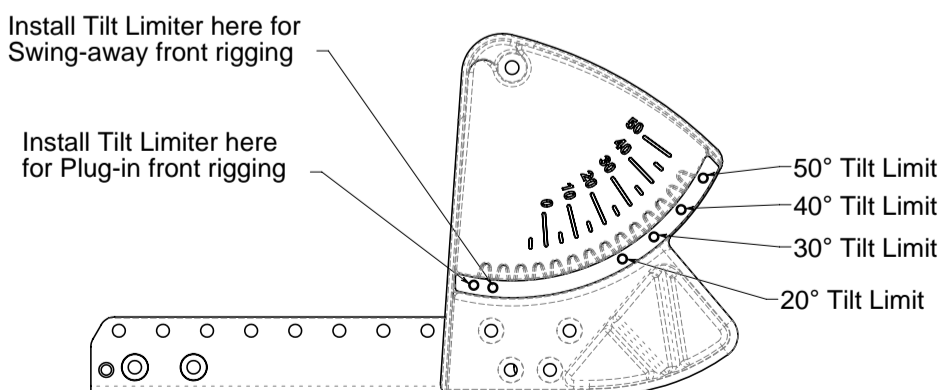

Figure 14.40: T50 Tilt Limit Adjustment

14.15 Gas Strut and Cable Assembly

14.15.1 Adjusting Cable Tension

Tilt cable wires stretch over time (or the sheath compresses) and can lead to tilt activation malfunctioning. To avoid this, the tension of the tilt cable wire needs to be adjusted over time to ensure proper tilting from the trigger activation.

IMPORTANT– Before adjusting – ensure the steel ball on the bottom end of the tilt cable is inserted into the actuating lever slot and that the cable is properly attached to the trigger.

To adjust the tension of the tilt cable wire:

1. If the chair does not tilt when the trigger is pulled – the cable wire is too loose and needs to be tightened. To do this, the cable wires height has to be lengthened. This adjustment is made by the height adjustment nut, as illustrated in Figure 14.41. Rotate the adjustment nut clockwise lengthening the sheath and thus tightening the cable wire.
2. Check tilt function and if acceptable tighten the height adjustment jam nut (Figure 14.41), securing the cable tension in place.
3. If the chair tilts without pulling the trigger – the cable is too tight and needs to be loosened. Reverse the procedure from above, have less thread show.

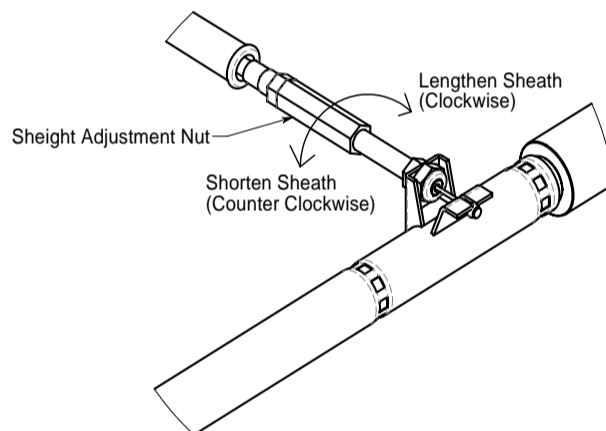

Figure 14.41: T50 Adjusting Cable Tension

Note: videos illustrating this adjustment are available on PDG Mobility's YouTube channel - <https://www.youtube.com/user/pdgmobility/>

14.15.2 Removing and Installing the Tilt Cable

To attach the tilt cable to the back post (trigger):

1. Grasp the cable just in front of the trigger. In one smooth motion, pull straight down until the cable releases from the end of the trigger. Pull the metal cable-end out from the side of the trigger.
2. Disconnect the opposite end of the cable from the strut, using a 7/16" and a 3/8" open end wrench.
3. To install the new cable, refit to the strut by reversing step 2. Be sure to connect the cable ball to the actuating lever.
4. Attach cable wire onto the mech-lock, slide steel ball through slot on lever (so ball is underside of the lever), see Figure 14.39 for reference.
5. Re-fit the metal cable end by inserting into the side of the trigger as shown in Figure 14.42 and feed the cable through to the trigger.

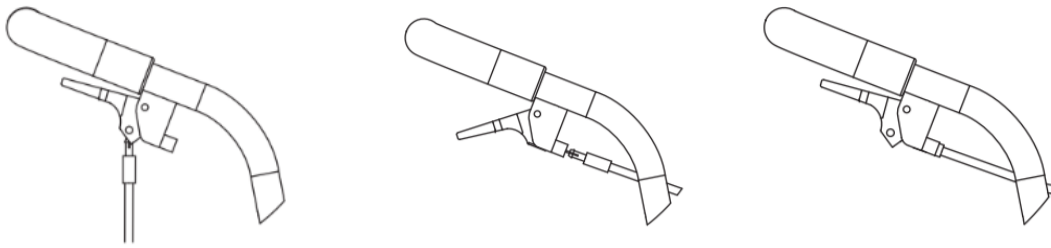

Figure 14.42: *Installing the cable*

6. Hold the plastic parts in place and pull the trigger. The cable should snap into place. If not, you may need to push the cable housing until it snaps into place.
7. Clip the cable onto the back posts using plastic clips provided.

Note: videos illustrating this adjustment are available on PDG Mobility’s YouTube channel - <https://www.youtube.com/user/pdgmobility/>

14.16 Headrest (Optional)

If your chair does not have a rigid backrest cushion, it may be fitted with a head rest mounting on the push bar handle. Otherwise, the head rest will be mounted directly to the rigid backrest.

Removing the Headrest

1. Loosen the “Headrest Height Adjustment Set Screw” and slide the head rest assembly upwards until it is free of the chair (see Figure 14.43).
2. To reinstall the headrest assembly, slide the headrest assembly back into the desired position and retighten the “Headrest Height Adjustment Set Screw”.

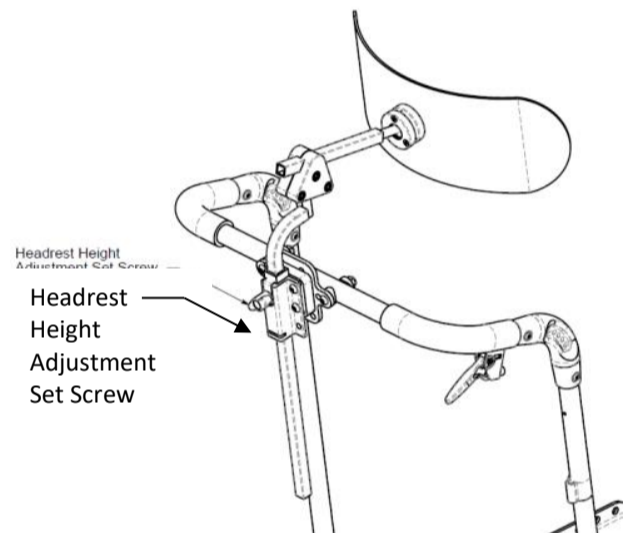

Figure 14.43: *Headrest*

Adjusting the Headrest Position

1. Refer to the manufacturer’s headrest manual to adjust the headrest position.

14.17 Postural Support Devices or Lap Belts (Optional)

WARNING- The lap belt is intended for use ONLY as a positioning aid for simple positioning needs, such as posterior pelvic tilt. The positioning belt **IS NOT** a transit restraint.

This belt will not be sufficient for persons with more involved positioning needs. Only your health care advisor can determine the proper positioning products for your situation. If used improperly, lap belts can cause severe injury or even death. If your health care advisor has instructed you to use lap belts, ensure they instruct you on the proper usage of such belts, and such professional should supervise your use of such belts to ensure you can use them safely.

1. Belts must fit snugly in order to work properly. However, they must not be so snug that they interfere with the occupants breathing. It should be possible to slide an open hand flat between the belt and body.

2. Make sure you do not slide down in your chair while wearing a belt. If this should happen, you may suffer chest compression or be suffocated due to pressure from the belt.
3. Do not use a positioning or seat belt unless you are capable of removing the belts easily in an emergency. If you cannot do this, consult with your health care advisor for other options to help with your posture.
4. There are devices that help to keep you from sliding down in the seat of your wheelchair, such as a pelvic wedge. Consult with your health care advisor to find out if you need to use such a device in conjunction with lap belts to mitigate the risks described above.
5. NEVER use lap belts as a motor vehicle restraint. These types of belts are NOT intended to protect the wheelchair rider from the forces involved in a vehicle accident, and they may, in fact, cause you to be injured. PDG highly recommends wheelchair users ALWAYS transfer to appropriate motor vehicle seating when traveling in a motor vehicle.

NOTE TO ATTENDANTS/ASSISTANTS - NEVER use postural support (lap belt) as a patient restraint (a restraint requires a doctor's order) or on a wheelchair user who is comatose or agitated.

14.18 Oxygen (O2) Tank Holder (Optional)

The Oxygen Tank Holder attaches to either the rear-right (shown) or rear-left corners of the lower frame. This option includes the Mount, Oxygen Tank Holder and all related hardware (the tank is not included).

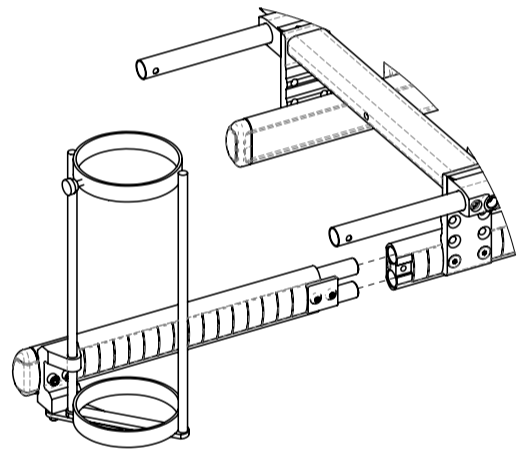

Figure 14.44: Oxygen tank holder

14.19 IV (Intravenous) Pole Mount (Optional)

The IV Pole Mount attaches to either the rear-right (shown) or rear-left corners of the lower frame. This option includes the Mount, IV Pole and all related hardware.

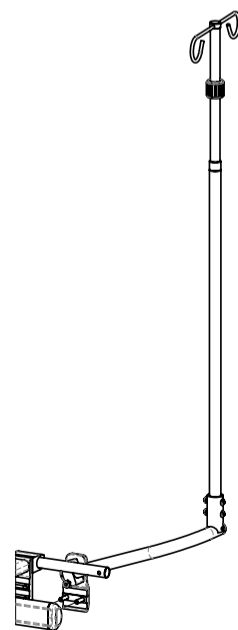

Figure 14.45: IV pole mount

14.20 Take-Apart Frame (Optional)

The Fuze T50, T50N and T50 Junior are both available with a Take-Apart frame option which allows for the upper frame of the wheelchair to be detached from the lower frame to help with transport and storage of the wheelchair

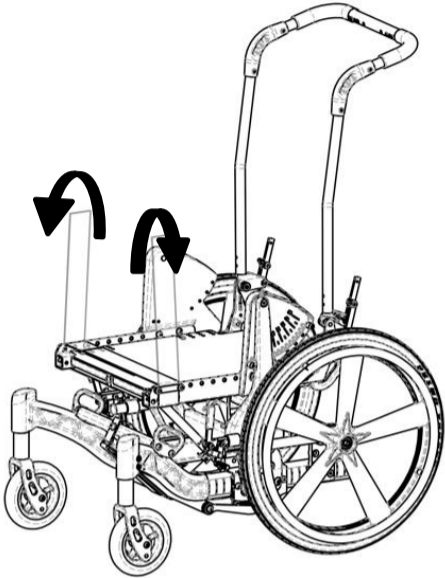

Figure 14.46: Take-Apart - Front Straps

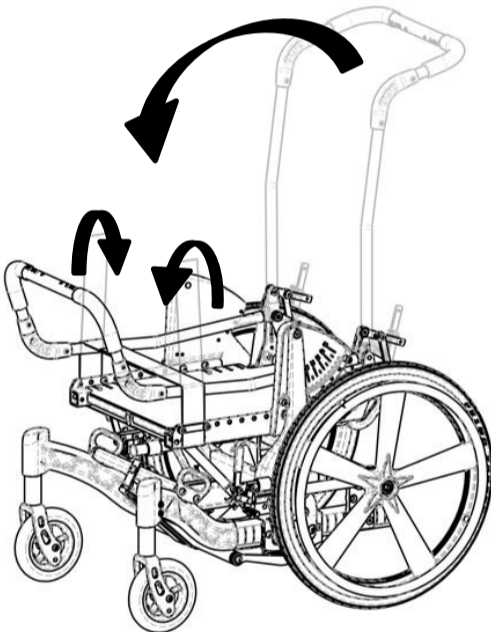

Figure 14.47: Take-Apart - Backrest Fold

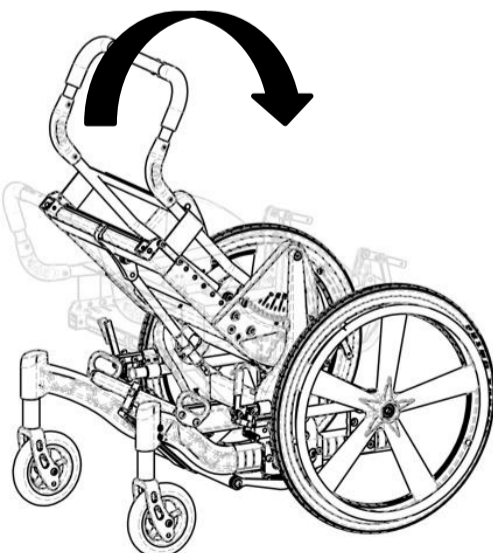

Figure 14.48: Take-Apart - Tilt

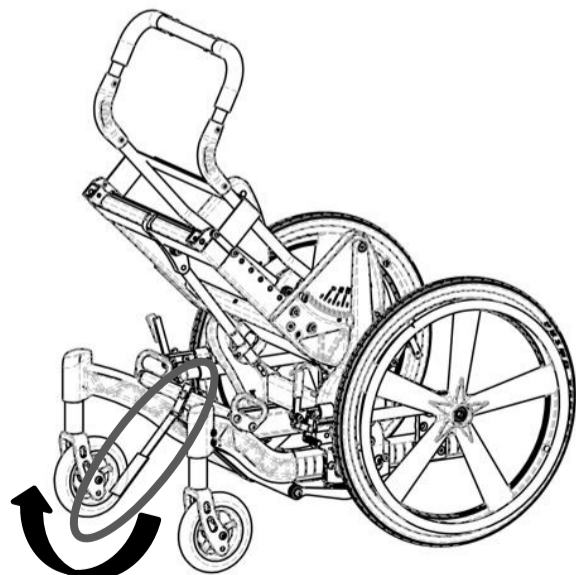

Figure 14.49: Take-Apart - Locking Strap

WARNING – HEAVY OBJECT – to avoid muscle strain or back injury, use lifting aids and proper lifting techniques when removing or replacing

WARNING – To prevent accidental disengagement, ensure foot release is fully locked and locking strap is fully tightened and secured before use of wheelchair

WARNING – Engage the wheel locks before disassembly and reassembly of the detachable upper frame

To remove the upper frame:

1. Engage Wheel Locks
2. Remove the front rigging, armrests, and seating as needed.
3. Unfold the front Velcro straps, typically located under the front edge of the seat cushion (Figure 14.46).
4. Fold down backrest and secure Velcro straps around backrest.
5. Tilt upper frame back to maximum tilt.
6. Un-hook removeable upper frame locking strap.
7. Step on release lever and remove upper frame. Rocking the frame either forwards or rearwards may ease removal.

DO NOT – rest the latching components of the lower frame on the ground during disassembly/reassembly

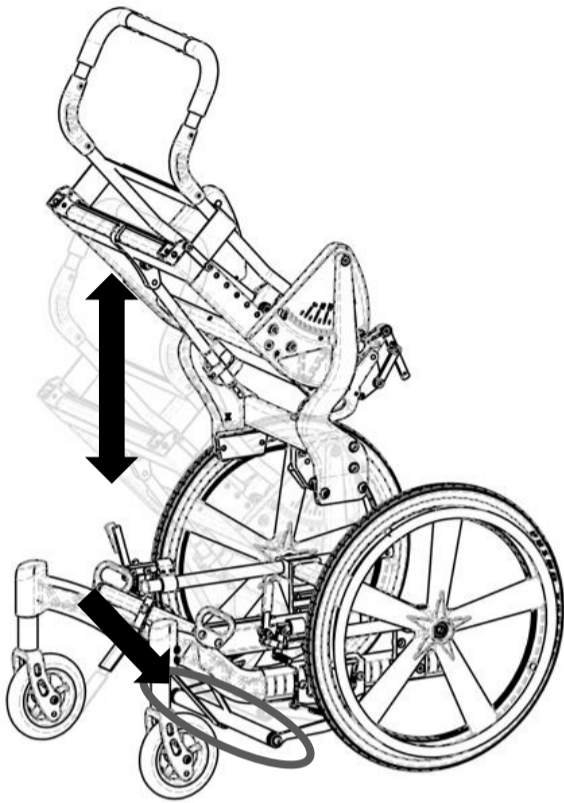

Figure 14.50: Take-Apart - Upper Frame Removal

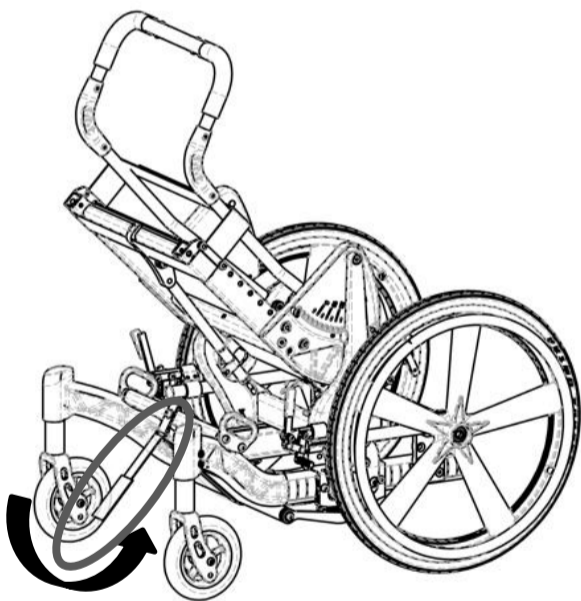

Figure 14.51: Take-Apart - Locking Strap Re-application

To reinstall the upper frame:

WARNING – HEAVY OBJECT – to avoid muscle strain or back injury, use lifting aids and proper lifting techniques when removing or replacing

1. Ensure the locking strap is loosened
2. Line up the upper frame pivot arm spades with the lower frame receivers and lower into place. The release lever will automatically activate and does not need to be stepped on at this time.
3. Ensure the upper frame is fully seated. Check that the release lever is in the locked position. The release lever crossbar should sit very close to the bottom of the lower frame. Rock the upper frame back and forth to ensure correct locking.

NOTE – If the upper frame is correctly latched in place, you will hear an audible click and the frame will not move when lifted or rocked back and forth.

4. Re-apply the locking strap

WARNING – Ensure locking strap is in good condition, with no rips, frays, etc. Do not use chair if locking strap is missing or damaged

5. Un-tilt the upper frame
Un-do the front straps, unfold the backrest, and place the front straps under the front of the seat cushion
6. Reinstall front rigging, armrests, seating, etc.

WARNING – To prevent accidental disengagement, ensure foot release is fully locked and locking strap is fully tightened and secured before use of wheelchair

WARNING – Do not assemble the wheelchair in the rearwards facing position. This chair has not been tested for stability in this configuration.

WARNING – Velcro straps are not restraints or positioning devices. Use Velcro straps only for securing backrest in location during disassembly of wheelchair.

NOTE – Periodically check the function of the latching mechanism and clear debris as needed. If lubrication is needed, use lithium grease or equivalent. **DO NOT** use penetrating oil to lubricate moving surfaces (i.e. WD-40)

14.21 Motor Vehicle and Transit Use

WARNING – Never use this wheelchair as a seat in a motor or transit vehicle unless it has been equipped with a Transit Tiedown System (TTS). When feasible and possible, the rider should transfer to the vehicle seat and use the vehicle-manufacturer-installed restraint systems, and the unoccupied wheelchair should be stored in a cargo area or secured in the vehicle during travel. Using a wheelchair not equipped with a TTS as a seat in a motor vehicle could result in serious injury or death.



Figure 14.52: hook symbol

To identify if your wheelchair has been manufactured with PDG’s Transit Tiedown System (TTS), look for the presence of the TTS indicated by 4 white hook symbols next to each tie down bracket.

The Fuze T50 wheelchair equipped with the Transit Tiedown System (TTS) has been tested according to, and passed, the **RESNA WC-4:2012, Section 19: Wheelchair used as seats in motor vehicles and ISO7176-19:2008 Wheelchairs – Part 19: Wheeled mobility devices for use as seats in motor vehicles**. These parts of RESNA and ISO standards address and evaluate the seating part of wheelchair-user occupant-protection systems for wheelchairs that may be used as a seat in motor vehicles as well as create compatibility with Wheelchair Tie-down and Occupant Restraint Systems (WTORS). Thus, for transportation in a vehicle the wheelchair must be restrained from movement using an RESNA WC-4:2017, section 18 wheelchair tiedown system (such as Q’strait S5-6329-11) and the vehicle must be equipped with an RESNA WC-4:2017, section 18 anchor points.

Not all configurations of the Fuze T50 wheelchair are compatible with the Transit Tiedown Systems (TTS). PDG manages the factory-built configurations and does not offer the Fuze T50 wheelchair except in compatible configurations. If changes are made to the wheelchair after it has left the factory, the wheelchair provider or PDG should be contacted to ensure it is appropriate to continue to use the wheelchair as a seat in a motor vehicle.

Aftermarket seating may have replaced the original equipment seat and back support designed and tested as part of the Transit Option. Your wheelchair provider should inform you if the seating provided with your wheelchair is original equipment or replacement aftermarket seating. A complete system of wheelchair frame, seating, Wheelchair Tie-Down and Occupant Restraint Systems (WTORS) and a properly equipped motor vehicle, that have all complied with the standards mentioned in this section, should be in place before using a Fuze T50 wheelchair equipped with the Transit Tiedown System as a seat in a motor vehicle.

If your wheelchair is NOT equipped with the Transit Tiedown System (TTS), the wheelchair DOES NOT meet ANSI/RESNA and/or ISO standards for motor vehicles seating and the following warnings should be observed:

1. NEVER let anyone sit in this chair while in a moving vehicle.
2. ALWAYS secure the wheelchair occupant with proper vehicle restraints. In an accident or sudden stop the rider may be thrown from the chair. Wheelchair restraints will not prevent this, and further injury may result from the belts and straps.

3. NEVER transport this chair in the front seat of a vehicle. It may shift and interfere with the driver.
4. ALWAYS secure this chair so that it cannot roll or shift.
5. Do not continue to use any wheelchair that has been involved in a motor vehicle accident.

If your chair is equipped with the Transit Tiedown System (TTS) the below instructions should be followed when the wheelchair is being used as a seat in a motor vehicle:

1. The wheelchair rider must be in a forward-facing position. The wheelchair has been dynamically tested in a forward - facing mode for a 48-mph frontal impact test.
2. The rider and all carried items must not weigh more than the chair's rated weight capacity.
3. The wheelchair occupant must use a Wheelchair Tiedown and Occupant Restraint Systems (WTORS) that complies with RESNA WC-4:2017, Section 18: Wheelchair tie-down and occupant restraint systems for use in motor vehicles or ISO 10542-1:2012, Technical systems and aids for disabled or handicapped persons -- Wheelchair tiedown and occupant-restraint systems -- Part 1: Requirements and test methods for all systems.
4. The Fuze T50 Transit Tiedown System is designed for a four-point (two in the front, two rear) strap-type tiedown system (Figure 14.53). Attach the WTORS in accordance with the manufacturer's instructions and RESNA WC-4:2012, Section 18 or ISO 10542-1:2012- Part 1.

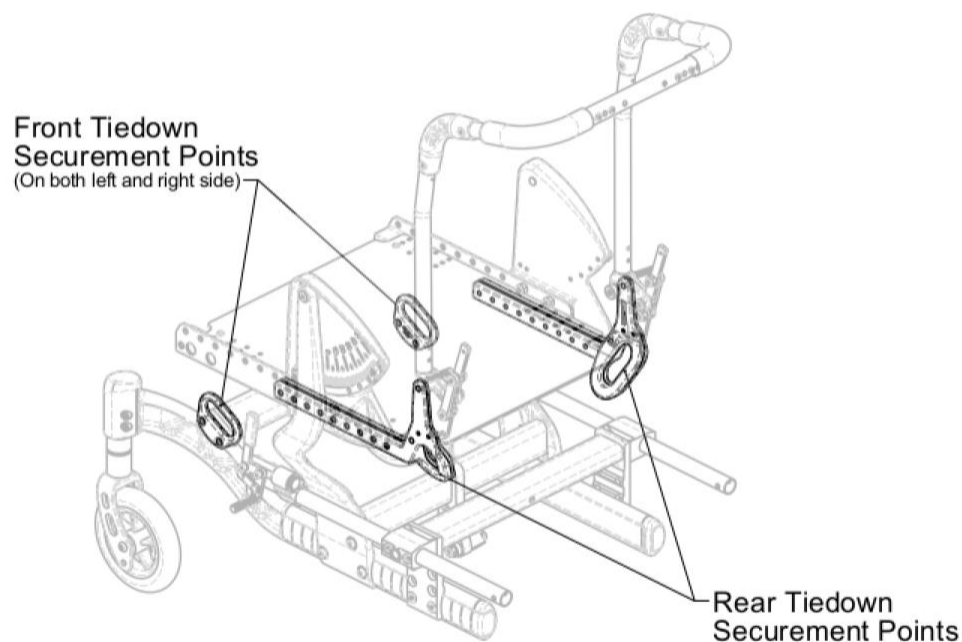

Figure 14.53: Fuze T50 Transit Tiedown 4 point securement location.

5. Postural supports (i.e. lap belts, chest straps, shoulder harnesses etc.) and positioning devices and accessories (i.e. headrests, lateral supports etc.) should not be used, or relied on for occupant restraint.
6. Any aftermarket seating should be tested and in compliance with RESNA WC-4:2012, Section 20 or ISO 16840-4:2009 – Part 4.

7. Attach the seating to the wheelchair frame in accordance with the seating manufacturer’s instructions and RESNA WC-4:2012, Section 20 or ISO 16840-4:2009 – Part 4.
8. Do not alter or substitute wheelchair frame parts, components or seating.
9. In order to reduce the potential of injury to vehicle occupants, wheelchair-mounted accessories, such as trays and respiratory equipment should be removed and secured separately.
10. Sudden stops or impacts can structurally damage your chair. Chairs involved in such incidents should be replaced.
11. Do not continue to use any wheelchair that has been involved in a motor vehicle accident.

CAUTION - If you fail to heed these warnings, ejection during an accident, damage to your chair, a fall, tip-overs or loss of control may occur and cause severe injury to the rider or others.

15 ISO 7176-15 TEST INFORMATION DISCLOSURE

Table 15.1: Fuze T50 wheelchair test configuration

Seat Width	450 mm
Seat Depth	430 mm
Backrest Height	580 mm
Wheelchair Weight	30 kg
Seat Sling	Solid seat pan
Back Upholstery	Sling type fabric, upholstered with light padding
Wheels	24" (600mm) urethane wheel
Casters	8" (200mm) plastic rim with pneumatic tire
Footrest	Easy-Out Plug-in, removable
Other options	Angle adjustable push handles, Removable, height adjustable, padded armrest
Mass of ATD	136kg (300lbs)
Max. User Weight	136kg (300lbs)

Table 15.2: Fuze T50 wheelchair performance values

Feature	Min	Max	Feature	Min	Max
Overall length with legrest	1170 mm	1170 mm	Seat plane angle	0°	50°
Overall width	550 mm	780 mm	Effective seat depth	380 mm	560 mm
Folded length	1170 mm	1170 mm	Effective seat width	330 mm	560 mm
Folded width	550 mm	780 mm	Seat surface height at front edge	330 mm	510 mm
Folded height	545 mm	720 mm	Backrest angle	0°	32°
Total mass	30 kg	30 kg	Backrest height	430 mm	580 mm
Mass of heaviest part	n/a	n/a	Footrest to seat distance	330 mm	610 mm
Static stability downhill	>10°	>10°	Leg to seat surface angle	0°	80°
Static stability uphill	>10°	>10°	Armrest to seat distance	420 mm	520mm
Static stability sideways	>10°	>10°	Front location of armrest structure	N/A	N/A
Energy consumption	n/a	n/a	Hand rim diameter	420mm	520mm
Dynamic stability uphill	n/a	n/a	Horizontal location of axle	N/A	N/A
Obstacle climbing	n/a	n/a	Minimum turning radius	785 mm	785 mm
Minimum braking distance from max speed.	n/a	n/a	Maximum speed forward	n/a	n/a

The wheelchair confirms to the following standards:

- a) Requirements and test methods for static, impact and fatigue (ISO 7176-8) Yes
- b) Requirements for resistance to ignition in accordance with (ISO 7176-16) Yes

The Fuze T50 wheelchair conforms to the test methods for static, impact and fatigue strength as required by ISO 7176-8.

16 LIMITED WARRANTY

PLEASE NOTE – THE WARRANTY BELOW HAS BEEN DRAFTED TO COMPLY WITH FEDERAL LAW APPLICABLE TO PRODUCTS MANUFACTURED AFTER JULY 4th, 1975.

This warranty is extended only to the original purchaser/user of our products.

This warranty gives you specific legal rights and you may also have other legal rights, which vary from state to state.

PDG offers warranty replacements for its product (except for third party accessories) to be free from defects in materials and workmanship for a period of one (1) year from date of purchase. The side frames and cross members are warranted for the lifetime of the original purchaser/user. If within such warranty period any such product shall be proven to be defective, such product shall be repaired or replaced, at PDG's option.

This Warranty does not include any labor or shipping charges incurred in replacement part installation or repair of any such product. PDG's sole obligation and your exclusive remedy under this warranty shall be limited to such repair and/or replacement.

PDG does not warranty third party accessories such as seat cushions, solid backrest, Dynamic Rocker Backs (DRB), belts, positioning straps etc. and recommends contacting the third-party manufacturer regarding warranty issues or product support for these options.

For warranty service, please contact the dealer from whom you purchased your PDG product. In the event you do not receive satisfactory warranty service, please write directly to PDG at the address on the back-cover page, provide dealer's name, address, and date of purchase, indicate nature of the defect and, if the product is serialized, indicate the serial number. Do not return products to our factory without our prior consent. Limitations and exclusions: the foregoing warranty shall not apply to serial numbered products if the serial number has been removed or defaced, products subjected to negligence, accident, improper operation, maintenance or storage, products modified without PDG's express written consent including, but not limited to, modification through the use of unauthorized parts or attachments; products damaged by reason of repairs made to any component without the specific consent of PDG, or to a product damaged by circumstances beyond PDG's control, and such evaluation will be solely determined by PDG. The warranty shall not apply to problems arising from normal wear or failure to adhere to these instructions. The foregoing express warranty is exclusive and in lieu of any other warranties whatsoever, whether express or implied, including the implied warranties of merchantability and fitness for a particular purpose, and the sole remedy for violations of any warranty whatsoever, shall be limited to repair or replacement of the defective product pursuant to the terms contained herein. The application of any implied warranty whatsoever shall not extend beyond the duration of the express warranty provided herein. The manufacturer shall not be liable for any consequential or incidental damages whatsoever. This warranty shall be extended to comply with state/provincial laws and requirements.

17 EUROPEAN UNION MDR INFORMATION



Class 1 Medical Device

PDG Fuze Manual Tilt Wheelchair

Basic UDI-DI: ++B829PDGWHEELCHAIRB7

Applies to the following models:

UDI-DI: B829151 (Fuze T50)

Manufactured starting July 2020

UDI-DI: B829261 (Fuze T50n)



Advena Ltd. Tower Business Centre, 2nd Flr.,
Tower Street, Swatar, BKR 4013 Malta



PDG Product Design Group Inc.
318 East Kent Avenue South
Vancouver BC V5X 4N6 CANADA



<http://pdgmobility.com>



PDG PRODUCT DESIGN GROUP INC.

#103- 318 East Kent Avenue South, Vancouver, BC V5X 4N6

Ph: (604) 323-9220 Fax: (604) 323-9097 E-mail: info@pdgmobility.com www.pdgmobility.com